

**DP1211 / 1311
DEKAPOT®**

Decade Potentiometer

User and Service Manual

Copyright © March, 2008 IET Labs, Inc.

DP1211/1311im/March,2008



IET LABS, INC.
formerly manufacturer by
esi/Tegam

534 Main Street, Westbury, NY 11590 www.ietlabs.com
TEL: (516) 334-5959 • (800) 899-8438 • FAX: (516) 334-5988

◆ PRECISION INSTRUMENTS FOR TEST AND MEASUREMENT ◆



IET LABS, INC.

534 Main Street, Westbury, NY 11590

www.ietlabs.com

TEL: (516) 334-5959 • (800) 899-8438 • FAX: (516) 334-5988

WARRANTY

We warrant that this product is free from defects in material and workmanship and, when properly used, will perform in accordance with applicable IET specifications. If within one year after original shipment, it is found not to meet this standard, it will be repaired or, at the option of IET, replaced at no charge when returned to IET. Changes in this product not approved by IET or application of voltages or currents greater than those allowed by the specifications shall void this warranty. IET shall not be liable for any indirect, special, or consequential damages, even if notice has been given to the possibility of such damages.

THIS WARRANTY IS IN LIEU OF ALL OTHER WARRANTIES, EXPRESSED OR IMPLIED, INCLUDING BUT NOT LIMITED TO, ANY IMPLIED WARRANTY OF MERCHANTABILITY OR FITNESS FOR ANY PARTICULAR PURPOSE.



WARNING



OBSERVE ALL SAFETY RULES
WHEN WORKING WITH HIGH VOLTAGES OR LINE VOLTAGES.

**Dangerous voltages may be present inside this instrument. Do not open the case
Refer servicing to qualified personnel**

HIGH VOLTAGES MAY BE PRESENT AT THE TERMINALS OF THIS INSTRUMENT

WHENEVER HAZARDOUS VOLTAGES (> 45 V) ARE USED, TAKE ALL MEASURES TO
AVOID ACCIDENTAL CONTACT WITH ANY LIVE COMPONENTS.

USE MAXIMUM INSULATION AND MINIMIZE THE USE OF BARE
CONDUCTORS WHEN USING THIS INSTRUMENT.

Use extreme caution when working with bare conductors or bus bars.

WHEN WORKING WITH HIGH VOLTAGES, POST WARNING SIGNS AND
KEEP UNREQUIRED PERSONNEL SAFELY AWAY.



CAUTION



DO NOT APPLY ANY VOLTAGES OR CURRENTS TO THE TERMINALS OF THIS
INSTRUMENT IN EXCESS OF THE MAXIMUM LIMITS INDICATED ON
THE FRONT PANEL OR THE OPERATING GUIDE LABEL.

6. Calibrate meter deflection.

Balance the dividers, then offset the standard divider by desired amount. Adjust the dc supply for the desired meter deflection.

7. Set both dividers to same value.

Read the linearity deviation on the calibrated meter.

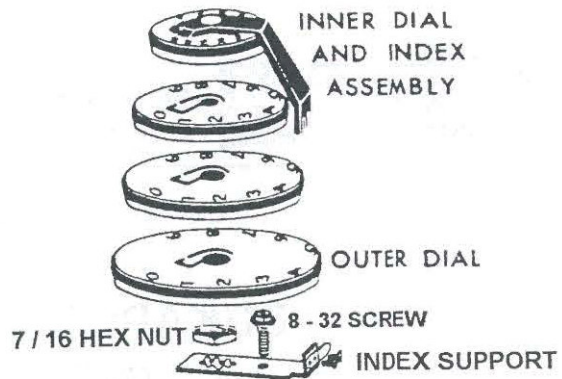

Mounting Instructions

REMOVE DIALS FROM CONTROL SHAFT

1. **Important:** Set all dials to zero before disassembling.
2. Loosen 2 index-mounting screws .
3. Turn inner dial to approximately 30 and loosen setscrew near number 50.
4. Turn inner dial to Wand loosen setscrew near number 80
5. Lift inner dial and index assembly straight off of shaft.
6. Loosen setscrew on each of the other dials.
7. Lift each dial straight off of shaft. On hermetically sealed units, remove all 'O' rings.
8. Remove 7/16 in. hexagonal nut.
9. Remove 8-32 screw and remove dial index support.

MOUNT THROUGH PANEL

10. Drill or punch panel mounting holes either for bushing mount or four -screw mount. See pane I mounting hole diagram.
11. Remove spacer discs, if necessary, to obtain effective panel thickness between 1/4 in. and 3/16 in. Each spacer is approximately 1/16 in. thick.
12. Insert DEKAPOT shaft and bushing through mounting hole.
13. Place index support and 7/16 in, nut over bushing and tighten finger-tight.
14. Rotate index support over hole below and to right of bushing.
15. Fasten index support to DEKAPOT through panel with 8-32 screw.

Mounting Panel

'O' Ring Seals



For Hermetically Sealed Units

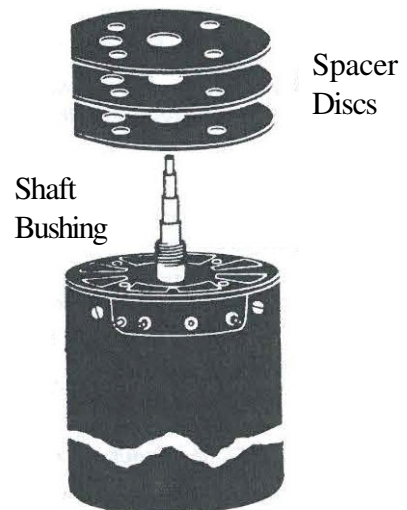

Mounting Holes

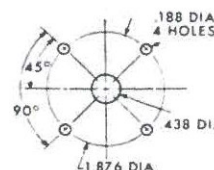

16. If four-screw mounting is used, insert and tighten three additional 8-32 mounting screws (may be already mounted) in appropriate holes.
17. Tighten 7/16 in. nut.

REASSEMBLE

18. Place the dials on the shaft. On hermetically sealed units install 'O' ring under each dial except the largest. Position the numbers so that 0 is at 9 o'clock dial index support should be between numbers 4 and 5. Do not tighten dials.
19. Place the inner dial and index assembly on the shaft with 00 lined up with index mark.
20. Line all dials up with index, being careful not to turn shafts under dials. If any dial turns the shaft, it will move a switch to a detented position. If this happens, turn the dial back to reset the switch, and try to slip it carefully to the proper position. If any dial is not lined up and will not slip easily on the shaft, remove the dials and try again to line them up as they are reassembled.
21. Pull outer dial slightly away from panel to avoid friction with bushing. Spread other dials apart evenly. On hermetically sealed units (before tightening setscrews), press dial so there is slight compression of 'O' ring seals. Tighten setscrews, being careful not to turn the dials. On the inner dial tighten only the setscrew near 8 (or 80).
22. Turn each dial except the outer dial through a complete revolution in order to check for zero. The outer dial should be blocked and not able to turn between 9 and 0. Intermediate dial (or dials) should have no detents between 9 and 0. Inner dial should feel slightly rough when turned through the numbered positions and should feel smooth in the blank area between 00 and the black triangle. There should be a slight detent at 00 on the inner dial.
23. Tighten setscrew near 50 on inner dial.

