

CERTIFIED
INDUSTRIAL SOUND LEVEL METER SET
IN ACCORDANCE WITH 42 CFR 82



NATIONAL INSTITUTE
FOR OCCUPATIONAL SAFETY AND HEALTH

Certificate No. TC-81-113 Issued to
Certified
Concord, Mass., U.S.A.

The certified set consists of the following parts:

Description	Part No.
Model 1982 Sound Level Meter	1982-9700
Microphone	1982-3000
Model 1562 or Model 1567 Sound Level Calibrator	1562-9701, or 1567-9701
Windscreen (Optional)	1690-7681
Microphone Extension Cable (Optional)	1933-0220
Instruction Manuals	1982-0100, 1562-0100, 1567-0100

LIMITATIONS

The Model 1982 sound level meter is certified by NIOSH for occupational noise measurements only when calibrated according to the instruction manual on the day of use before and after a sound level measurement period by a Model 1562 or Model 1567 sound level calibrator. Certification of the sound level meter applies only to use of the A-weighting network and the slow response meter characteristic.

Model 1982 Sound Level Meter Microphone Configurations not Certified by NIOSH:

- Model 1982 (1982-9700) sound level meter with flat random incidence response microphone (1982-3000), microphone extension cable (1933-0601), and with or without windscreen (1690-7681).
- Model 1982 (1982-9710) sound level meter with flat perpendicular incidence response microphone (1982-9802).

GR1562

SOUND-LEVEL CALIBRATOR

Form 1562-0100-00

This instrument is capable of calibrating sound-level meters used for measurements required under Part 1910.95 "Occupational Noise Exposure," (Dept. of Labor) of the Code of Federal Regulations, Chap. XVII of Title 29 (36 F. R. 7006).

This instrument carries U.S. Bureau of Mines, Mining Enforcement Safety Administration approval for use in methane-air mixture only. Approval Number 2G-2263.



IET LABS, INC.
534 Main Street
Westbury, NY 11590

www.ietlabs.com 516-334-5999 Fax: 516-334-5988

This book contains the instructions for the Type 1562 Sound-Level Calibrator. Detailed information on noise-measuring techniques and sound-measuring equipment associated with such a calibrator can be found in the General Radio "Handbook of Noise Measurement."

REPLACEMENT 9-V BATTERIES

<i>Manufacturer</i>	<i>Manufacturer's Part Number</i>
Bright Star	0918
Burgess	PM6 or P6
Eveready	226
Mallory	M-1600
Marathon	1600A
Neda	1600
Philco	P91
Ray-O-Vac	1600
RCA	VS300A
Sears	6418
Varta*	29
Wizard	7D7600
Zenich	Z226

*Instruments with ID2655 and greater will accept this battery.

TABLE OF CONTENTS

Section 1 INTRODUCTION

- 1.1 Purpose 1
- 1.2 Description 2

Section 2 OPERATING PROCEDURE

- 2.1 Preliminary Checks 11
- 2.2 Calibration of Sound-Measuring Instruments 13
- 2.3 Calibration of Sound-Level Meters 18
- 2.4 Altitude and Pressure Corrections 23

Section 3 PRINCIPLES OF OPERATION

- 3.1 The Wien-Bridge Oscillator 26
- 3.2 Acoustical Output Circuit 29
- 3.3 Electrical Output Circuit 30
- 3.4 Battery Check Circuit 30
- 3.5 Starting Circuit 31

Section 4 SERVICE AND MAINTENANCE

- 4.1 Warranty 32
- 4.2 Service 33
- 4.3 Removal of the Instrument Cover 33
- 4.4 Minimum Performance Standards 33
- 4.5 Trouble-Analysis 36
- 4.6 Replacement of Defective Parts 38
- 4.7 Calibration Check 38

1.2 DESCRIPTION.

1.2.1 GENERAL.

Figure 1-1 shows the Type 1562 with its adaptors, and Table 1-1 documents the type and function of the control and accessories.

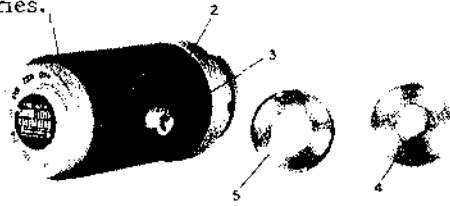

Figure 1-1. Type 1562 Sound-Level Calibrator.

Table 1-1			
Controls and Accessories			
Fig. 1-1 Ref.	Name	Type	Function
1	OFF-START-FREQUENCY	7-position selector switch	Turns instrument on. Checks battery. Selects frequency.
2	Knurled nut	Tubular	Holds shield on instrument.
3	Electrical Output	Phone Jack	Provides 1 volt $\pm 20\%$ sine wave output at each frequency.
4	Microphone Adaptor	(P/N 1562-6130)	Adapts instrument to 1/2 inch diameter microphone.
5	Microphone Adaptor	(P/N 1562-6100)	Adapts instrument to 1 inch diameter microphone.
—	Battery	9 V Burgess PM6 or equivalent	Power for instrument.
—	Case	—	Holds instrument and accessories.

2

As shown in the block diagram of Figure 1-2, the instrument consists of an oscillator which drives a loudspeaker to generate high-level acoustic calibrating signals in a coupler that fits over the measurement microphone. Figure 1-3 shows the coupling end of the instrument. Various diameter microphones will probably be involved at times, and Figures 1-4, 1-5, and 1-6 are provided to show mounting position of typical microphones.

1.2.2 THE OSCILLATOR.

The oscillator is a battery-operated Wien-bridge transistor oscillator that generates five ANSI-preferred frequencies, 125, 250, 500, 1000, and 2000 Hz. The oscillator operates from a 9-volt battery and is very stable, has low distortion, and low noise.

1.2.3 ACOUSTIC OUTPUT.

The oscillator drives a small controlled-reluctance magnetic loudspeaker. The loudspeaker drives one end of a small acoustic coupler. The other end of the coupler is closed by the microphone to be calibrated. A controlled leak to atmosphere in the wall of the coupler is adjusted so that constant voltage across the loudspeaker terminals generates essentially constant sound-pressure level in the coupler from below 100 Hz to 1000 Hz. Above 1000 Hz the response

3

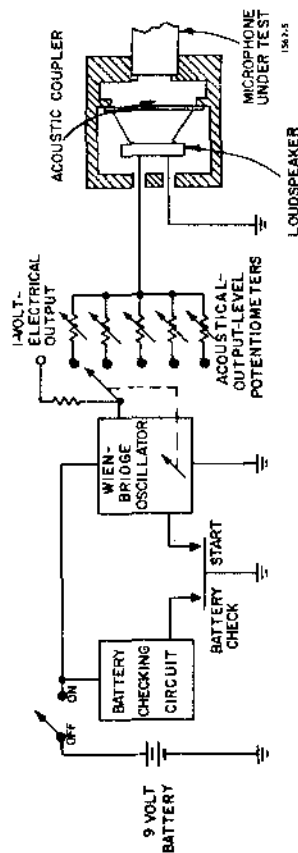

Figure 1-2. Functional block diagram of the Type 1562 Sound-Level Calibrator.

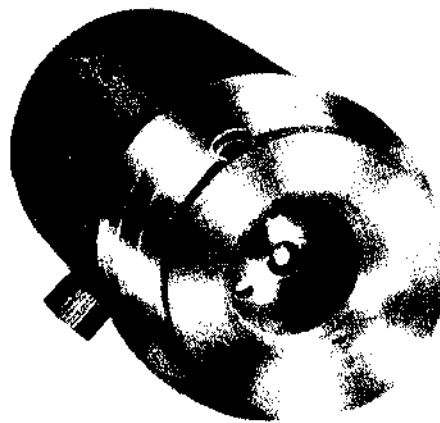

Figure 1-3. Acoustic coupler of Type 1562

falls off at approximately 12 dB per octave. The oscillator output voltage is the same at each frequency, so at each frequency a voltage divider is used to set the sound-pressure level in the coupler to 114 dB re 20 microneutons per meter^{2*} as measured by a laboratory standard microphone (W. E. Type 640-AA).

1.2.4 OUTPUT ADAPTORS.

The coupler that makes up the output is designed to fit over the Types 1560-P3 and

*A newton per square meter is the unit of pressure and it is equal to 10 dynes per square centimeter; in the international system of units (SI), it is the Pascal (Pa).

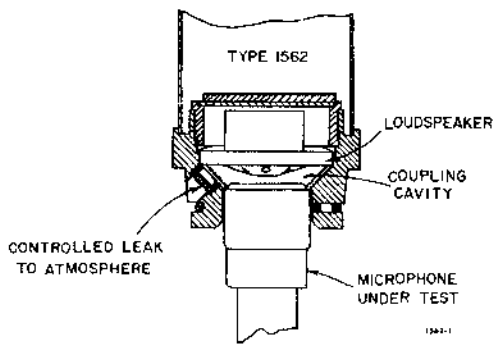

Figure 1-4. Calibration mounting position of GR Types 1560-P1, -P3, or -P4 microphones.

-P4 (1 1/8-inch diameter) microphones. These microphones were used for many years on sound-level meters and other sound-measuring equipment. There is still a large number in use throughout the industry. They also have the largest outside diameter of any widely used measurement microphone. Newly designed or special-measurement microphones are generally smaller in diameter, and it is usually much easier to design adaptors to reduce the diameter of the coupler fitting than it is to effect an increase in its diameter.

The most common smaller diameter microphones are the Types 1560-P5 and -P6 Piezoelectric Ceramic Sound-Level Meter Microphones currently supplied on General Radio sound-measuring instruments. The diameter of these microphones is 15/16 inch.

This is also the diameter of the USASI Type L Laboratory Standard Microphone embodied in the Western Electric Type 640-AA Microphone.

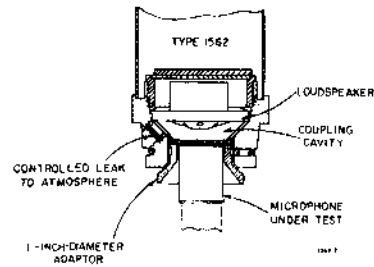

Figure 1-5. Calibration mounting position of GR Types 1560-P5, -P6 microphones with 1-inch diameter adaptor.

Smaller diameter microphones often associated with sound measurements are those in the Altec 21BR series supplied with the Type 1551-P1L and 1551-P1H Condenser Microphone Systems. These microphones have an outside diameter of 5/8 inch.

Snap-in adaptors for 1-in.-dia., and for 1/2-in.-dia. microphones are included with the Type 1562 calibrator so that most measurement microphones can be accurately and con-

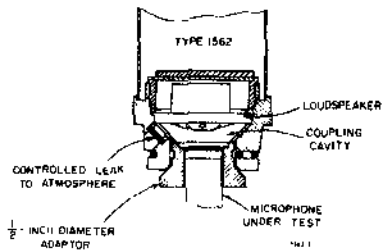

Figure 1-6. Calibration mounting position of GR microphones with $\frac{1}{2}$ -inch diameter adaptor.

veniently checked. Each adaptor is designed to maintain a constant volume in the coupler so that the sound level generated therein is always 114 dB when the barometric pressure is 760 mm of mercury.

1.2.5 ELECTRICAL OUTPUT.

The electrical output voltage of the oscillator is available at the phone jack on the side of the calibrator. The tubular knurled nut which secures the instrument cover, forms the shell of a standard telephone jack. The open-circuit output voltage at this point is nominally one volt in back of a source resistance of 6000 ohms. The actual value of this voltage for any calibrator is constant over the instruments frequency range and

8

independent of normal environment conditions and battery voltages. The generated output is a sinewave with less than 0.5% distortion.

The tolerances on the characteristics of the thermistor (R133), which determines the operating level of the oscillator, permit operating levels among oscillators to differ by $\pm 20\%$. Each oscillator will operate, however, at the constant level dictated by its thermistor.

1.2.6 BATTERY CHECKING CIRCUIT.

The operation of the calibrator oscillator is independent of the battery voltage as long as it remains at 6 volts or higher. The battery-checking circuit is included in the instrument so the operator can quickly determine if his battery is safely in the operating range. When the calibrator dial is turned to the spring return, counter-clockwise position, the lamp (P101) will light only if the battery voltage is 6 volts or higher. If the battery is below 6 volts the transistor switch remains open and the lamp will not light. Since the lamp load is much higher than the normal oscillator load on the battery, the battery must also be in good condition or its voltage will drop below the lamp ignition level during the battery check of one or two seconds, because of the excess load.

9

1.2.7 CONTROLS AND CONNECTORS.

MASTER CONTROL

The master control is the plastic combination knob, dial, and nameplate at the top of the instrument. This control is used to turn the instrument on, check the battery condition, and select the operating frequency. A red background area illuminates the transparent engraving to indicate the dial setting.

ACOUSTIC-OUTPUT COUPLING

The acoustic output from the calibrator is obtained at the bottom of the instrument, at the opposite end from the main control. The correct acoustic output is obtained when a 1 1/8-inch-diameter microphone, or smaller diameter microphone in a 1 1/8-inch-diameter adaptor is properly seated in the 1 1/8-inch-diameter recess at the bottom of the calibrator.

Section 2

OPERATING PROCEDURE

2.1 PRELIMINARY CHECKS.

2.1.1 BATTERY CHECK.

Install the battery in the instrument by removing the cover (paragraph 4-3) and connecting the battery between the battery clips. Replace the cover.

With the instrument upright on a desk or bench and the output phone jack connector facing the operator, the master control should be in the position shown in Figure 2-1. That

is, the nameplate should be oriented for proper reading and OFF should be illuminated by the red backing area. To check the battery, turn the knob momentarily counter-clockwise against the spring return and observe that the small lamp at the 3:00 o'clock position lights. If the lamp doesn't light when the dial is turned against the spring return, repeat a second time. If there still isn't any light refer to Section 4 of this book.

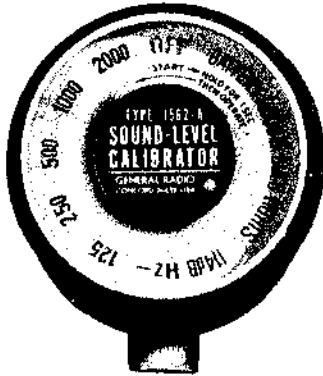

Figure 2-1. Top view of calibrator with master control OFF.

2.1.2 OPERATIONAL CHECK.

Turn the Type 1562 on by rotating the master control counter-clockwise against the spring return, as when checking the battery, and holding it for approximately one second,

Turn the knob clockwise to the 2000-Hz position. A clear 2000-Hz tone should be easily audible. If a more raucous tone is heard it will be necessary to hold the knob in the START position a little longer before setting it to 2000 Hz. One second or so is usually long enough at normal room temperatures; however, at low temperatures the knob must be held in the start position somewhat longer to ensure proper starting of the oscillator.

When the clear 2000-Hz tone is heard, the calibrator is ready for use and can be set to any of its five frequencies without repeating the starting procedure.

2.2 CALIBRATION OF SOUND-MEASURING INSTRUMENTS.

The Type 1562 Sound-Level Calibrator is adjusted to develop a constant sound-pressure level of 114 dB re 20 micronewtons per meter² at each of five frequencies (125, 250, 500, 1000, and 2000 Hz), when its acoustic coupler is placed over a high (acoustic) impedance sound-measuring microphone. This level is established by adjusting the calibrator output to register a 114-dB sound-pressure level on a sound-measuring system using a carefully maintained laboratory standard microphone, such as the Western Electric 640-AA, with a pressure calibration determined by reciprocity and traceable to the National Bureau of Standards. This calibration is performed at a temperature of 23°C and an atmospheric pressure of 760 mm of Hg. Normal variation of temperature and

atmospheric pressure will have negligible effect on the sound-pressure level developed. The specifications give the value of the temperature coefficient, and the curves in Figure 2-2 show the variation of sound-pressure level with atmospheric pressure.

So long as the volume enclosed by the coupler is kept constant, including the effective volume of the microphone to be calibrated, the sound-pressure level developed in the calibrator coupler is constant at 114 dB. The adaptors supplied with this calibrator are designed so that most of the commonly used measurement microphones are calibrated at the 114 dB sound-pressure level. Tables 2-1 and 2-2 list commonly used sound-measuring microphones. The appropriate calibrator adaptor, microphone adaptor if required, and the sound-pressure levels developed by the calibrator for each microphone are also tabulated. The levels listed in Tables 2-1 and 2-2 are sound-pressure levels and are the levels that would be indicated by a measuring system using a microphone with a flat pressure response, plus amplifiers and meters with flat frequency characteristics. Many sound-measuring systems (i.e., sound-level meters, see paragraph 2.3.1) are designed to have other than flat pressure response, so that the levels given in Tables 2-1 and 2-2 must be adjusted to account for the desired response of the measuring system. The procedure for calibrating sound-level meters will be explained in the following paragraphs.

14

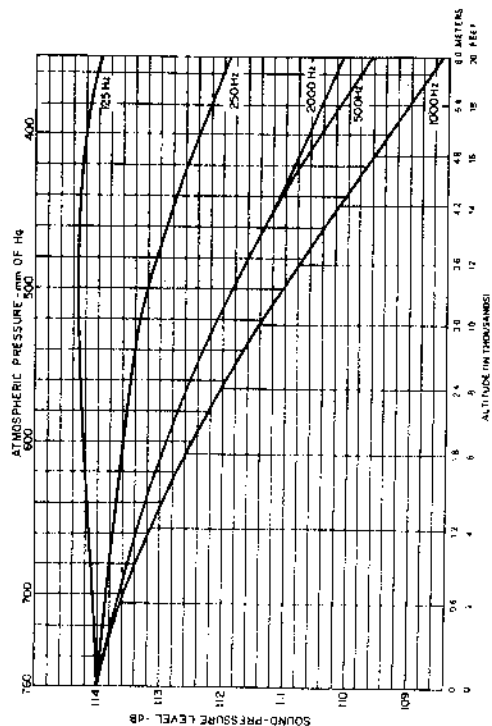

Figure 2-2. Variation of sound-pressure level in relation to changes in atmospheric pressure and altitude.

15

Table 2-1
SPL Deviations for Microphones Assuming Flat Pressure Response¹

Mfg.	Microphone Type	Protective Grid	Adaptor		Sound-Pressure Level (dB)/Frequency Hz				
			No. 1562-	Diameter Inches	125	250	500	1000	2000
W. E.	640-AA	ON	6100	0.939	114.0	114.0	114.0	114.0	114.0
W. E.	640-AA	OFF	6100	0.939	114.0	114.0	113.8	113.7	113.5
B&K	4131/32	ON	6100	0.939	113.4	113.3	113.2	113.2	113.2
B&K	4131/32	OFF ²	6100 ³	0.939	114.0	114.0	113.8	113.8	113.4
B&K	4131/32	OFF ²	6100 ⁴	0.939	114.0	114.0	114.0	114.0	114.0
B&K	4133/34	ON	6100*	0.52	114.0	114.0	114.0	114.0	114.0
B&K	4135/36	ON	6100*	0.275	114.0	114.0	114.0	114.0	114.0
B&K	4138	ON	6100*	0.140	114.0	114.0	114.0	114.0	114.0
TOKYORIKO	MR103	ON	6100	0.939	114.0	114.0	114.0	114.0	114.0
TOKYORIKO	MR103	OFF	6100	0.939	114.0	114.0	113.8	113.7	113.5
ALTEC	BR series	ON	6110	0.628	114.1	113.9	113.9	114.0	113.5

1. Measurement conditions: Atmospheric Pressure - 760 mm of Hg; Temperature - 23°C.

2. Additional B & K coupler adaptor needed.

3. B & K coupler adaptor DB0111 used.

4. B & K coupler adaptor (with protective grid) DB0014 used.

* Require additional adaptors from GR Set 1560-9561.

Table 2-2
SPL Deviations for Microphones Assuming Flat Pressure Response¹

Mfg.	Microphone Type	Protective Grid	Adaptor		Sound-Pressure Level (dB)/Frequency (Hz)				
			No. 1562-	Diameter Inches	125	250	500	1000	2000
GR	1560-9570	ON	6100	0.939	114.1	113.9	114.0	113.9	114.0
GR	1560-P5, P6, P7	ON	6100	0.939	114.1	113.9	114.0	113.9	114.0
GR	1560-P3 ²	ON	NONE	1.125	114.0	114.0	114.0	113.9	114.3
GR	1560-P4 ²	ON	NONE	1.125	114.0	114.0	114.0	113.9	114.3
GR	1560-P1 ³	ON	NONE	1.125	114.0	114.0	114.0	113.9	114.3
GR	1551-P1L	ON	6110	0.628	114.1	113.9	113.9	114.0	113.5
GR	1551-P1H	ON	6110	0.628	114.1	113.9	113.9	114.0	113.5
GR	1961	ON	6100	0.939	114.1	114.1	114.1	114.1	114.1
GR	1962	ON	9601	0.500	114.0	114.0	114.0	114.0	114.0
GR	1963	ON	9602	0.275	114.0	114.0	114.0	114.0	114.0
GR	1971	ON	6100	0.939	114.1	113.9	114.0	113.9	114.0
GR	1972	ON	9601	0.500	114.0	114.0	114.0	114.0	114.0

1. Conditions: Atmospheric Pressure - 760 mm of Hg; Temp - 23°C. 2. Shure 98108 Microphone.

3. Shure 9898 Microphone.

2.3 CALIBRATION OF SOUND-LEVEL METERS.

2.3.1 GENERAL.

Sound-level-meter microphones manufactured in the United States are usually adjusted to have nominally flat response to sounds of random incidence in a free-field. The response of the amplifier in the sound-level meter is modified to obtain the required weighting characteristics. To determine what a sound-level meter should read when the Type 1562 is coupled to its microphone, one must correct for the difference between the microphone random-incidence, free-field response and its pressure response, and for the difference between a flat-amplifier response and the weighted-amplifier response.

Microphone-calibration response curves supplied by General Radio Company are for the free-field, random-incidence response. The Type 1559-B Reciprocity Microphone Calibrator also yields the free-field random incidence response of the microphone. Corrections of perpendicular-incidence and random-incidence responses to the pressure responses of General Radio microphones are given in Table 2-3. ANSI weighting characteristics for sound-level meters from the USA Standard Specification for Sound-Level Meters, S1.4, 1971, are listed in Table 2-4 for the five calibrator frequencies.

Table 2-3
Pressure Response Corrections for GR Microphones 1
(dB to be added to perpendicular-incidence and random-incidence free-field responses)

Microphone Type	1560-P5, -P6, 1961 1560-970		1560-P3, -P4		1551-P1L, H		1962	
	Frequency (Hz)		Frequency (Hz)		Frequency (Hz)		Frequency (Hz)	
Incidence to Pressure	1000	2000	1000	2000	1000	2000	1000	2000
	-0.1	-1.1	-0.3	-1.7	0	-0.4	-0.2	-0.5
Perpendicular Random	0	-0.3	-0.1	-0.5	0	-0.1	-0.6	-0.2

i. Measurement conditions: Atmospheric pressure -- 760 mm of Hg; Temperature -- 23°C.

Table 2-4

Deviations in dB from Flat Response for Sound-Level Meter Weighting ¹					
Weighting	Frequency (Hz)				
	125	250	500	1000	2000
C	-0.2	0	0	0	-0.2
B	-4.3	-1.4	-0.3	0	-0.2
A	-16.2	-8.6	-3.3	0	+1.2

1. Measurement conditions:
 Atmospheric pressure - 760 mm of Hg
 Temperature - 23°C

**2.3.2 CALIBRATION OF TYPE 1551-C OR
 TYPE 1565 SOUND-LEVEL METERS
 WITH TYPE 1560-P5, -P6 MICRO-
 PHONE OR TYPE 1560-2131 MICRO-
 PHONE CARTRIDGE.**

For detailed calibration procedures on individual GenRad instruments, refer to the instruction manual for the particular instrument.

Table 2-5

Design-Center Readings in dB for Sound-Level Meters using 1 inch Diameter Microphones ¹ (Type 1560-P5, -P6, -P7 or 1560-9570 Cartridge)					
Weighting	Frequency (Hz)				
	125	250	500	1000	2000
C	113.8	113.9	114.0	113.9	113.5
B	109.7	112.4	113.7	113.9	113.5
A	97.8	105.3	110.7	113.9	114.9

1. Measurement conditions:
 Atmospheric Pressure - 760 mm of Hg
 Temperature - 23°C

NOTE

Tables 2-5 and 2-6 list Design-Center Readings for sound-level meters using GR microphones. For sound-level meters adjusted to read correctly at 500 Hz, the allowable variations from the values given in Tables 2-5 and 2-6 for a meter meeting the ANSI Standard Specifications for Sound-Level Meters, SI.4, 1971, are ± 2 dB (± 1.5 dB from the specification tolerances and ± 0.5 dB from the calibrator tolerances) at 1000 Hz and ± 3 dB (± 2.5 dB from the specification tolerances and ± 0.5 dB from the calibrator tolerances) at 2000 Hz. For the GR Type 1560-P5 and -P6 Microphones, these variations from the values of Table 2-5 should not exceed ± 1.3 dB (± 0.8 dB ± 0.5 dB) at 1000 Hz and ± 1.8 dB (± 1.3 dB ± 0.5 dB) at 2000 Hz. For the GR Type 1560-P7 Microphone, these variations should not exceed ± 1.3 dB (± 0.8 dB ± 0.5 dB) at 1000 Hz and 2000 Hz.

In Table 2-6 the GR Type 1560-P3 and -P4 Microphone variations should not exceed ± 1.5 dB (± 1.0 dB ± 0.5 dB) at 1000 Hz and ± 2.0 dB (± 1.5 dB ± 0.5 dB) at 2000 Hz.

Table 2-6

Design-Center Readings in dB for Sound-Level Meters using 1 1/8 Inch Diameter Microphones ¹ (Type 1560-P1, -P3, -P4, Shure 9898, or Shure 98108)					
Weighting	Frequency (Hz)				
	125	250	500	1000	2000
C	113.8	114.0	114.0	113.8	113.6
B	109.7	112.5	113.7	113.8	113.6
A	97.8	105.4	110.7	113.8	115.0

1. Measurement conditions:
 Atmospheric Pressure - 760 mm of Hg
 Temperature - 23°C

2.3.3 CALIBRATION OF TYPE 1551 SOUND-LEVEL METERS WITH 1560-P1 OR -P3 MICROPHONES.

Refer to SLM manual for details.

2.3.4 CALIBRATION CHECKS ON TYPE 1563.

Refer to SLM manual for details.

2.3.5 CONDENSER MICROPHONE SETS.

A special set of adaptors (P/N 1560-9561) is available as an accessory to permit calibration of five combination microphone/preamplifier sets utilizing small diameter condenser microphones. They are sets P/N 1560-9532 through -9536, ranging in size from 1/2 to 1/8 inch. The adaptors nest into one another to get down to the smaller sizes and ultimately mate with calibrator through the 1-inch adaptor, P/N 1562-6100. Operation is otherwise the same as for ceramic microphones.

CAUTION

Don't confuse the slight resistance of an internal O-ring in the smaller adaptors for true bottoming.

2.4 ALTITUDE AND PRESSURE CORRECTIONS.

The Type 1562 is subject to altitude and atmospheric pressure changes in relation to its acoustical output. A graph has been plotted (Figure 2-2) to show the change in sound-pressure level with a change in altitude and

atmospheric pressure. Each frequency has its own curve to be used when determining the output level at a specific altitude or pressure. The pressures given by the United States Weather Bureau and by various flight facilities are corrected pressures, i.e., pressures referred to sea level. Most barometers are similarly calibrated to read pressures corrected to sea level. The actual barometric pressure can be specifically requested of your local weather station, or you can correct the published barometric reading for your own location. This correction is a function of altitude, temperature, and pressure, but the principal factor is the altitude correction of one inch of mercury per 1000 feet above sea level. The Appendix includes an altitude correction chart and a conversion nomograph for inches of mercury to millibars, along with a table of altitudes above sea level for selected cities in the U.S. and Canada.

NOTE

When the curves of Figure 2-2 are used to determine the acoustical output of the calibrator at high altitudes, an additional tolerance of ± 0.1 dB per 4000 feet of elevation must be added to the existing specification tolerance.

Two examples of how to use the graph are:

24

- a. Conditions of measurement:
Frequency, 250 Hz
Altitude, 8000 feet
Microphone, Western Electric
640-AA

Solution by graph:
Instrument tolerance from specification, ± 0.5 dB
Graph sound-pressure level and tolerance,
113.5 ± 0.2 dB
Final acoustical output, 113.5 ± 0.7 dB

- b. Conditions of measurement:
Frequency, 500 Hz
Altitude, 18000 feet
Microphone, Western Electric
640-AA

Solution by graph:
Instrument tolerance from specification, ± 0.3 dB
Graph sound-pressure level and tolerance,
110.2 ± 0.45 dB
Final acoustical output, 110.2 ± 0.75 dB

This final acoustical output is the value of sound-pressure level that will be generated by the calibrator under the stated measurement conditions.

25

PRINCIPLES OF OPERATION

3.1 THE WIEN-BRIDGE OSCILLATOR.

3.1.1 GENERAL.

The Wien-bridge circuit (Figure 3-1) used in this oscillator performs two functions. Two of the bridge arms (C105, R_{F1} and C104, R_{F2}) form a frequency determining impedance divider which provides positive feedback to sustain oscillation. The remaining two arms (R133 and R108), form a resistive divider which provides negative feedback to stabilize the amplitude.¹

1. For a detailed discussion of this design feature, see Fulks, R.G., "Novel Feedback Loop Stabilizes Audio Oscillator", Electronics, Vol. 36 No. 5 February, 1963. Available as General Radio reprint A-107.

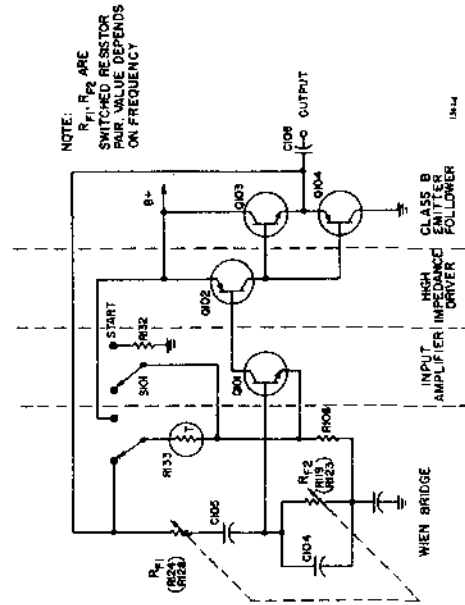

Figure 3-1. Simplified schematic diagram of oscillator in Type 1562 Sound-Level Calibrator.

3.1.2 FREQUENCY AND STABILITY.

The operating frequency of a Wien-bridge oscillator depends on the values of the components in the impedance divider. In the Type 1562, capacitors C104 and C105 (Figure 3-1) are equal and remain at a constant value. Resistors R_{F1} and R_{F2} are also equal, but are switched in value to establish the frequency of oscillation. This frequency-determining network has a transfer function:

$$\frac{e_{OUT}}{e_{IN}} = \frac{RCS}{1+3RCS+R^2C^2S^2}$$

$$\text{where } S = j2\pi F$$

$$R = R_{F1} = R_{F2}$$

$$C = C105 = C104$$

At the oscillator frequency ($f_o = \frac{1}{2\pi CR}$) this function equals +1/3. The net loop gain should be +1 for proper and stable operation, so the resistive divider consisting of R133 and R108 is used to set the associated amplifier gain to +3. This gives a net loop gain of +1 and the circuit oscillates at the desired frequency. R133, a thermistor, automatically adjusts its resistance to the value needed to maintain oscillations. Its time constant is short enough to provide rapid correction for amplitude variations, yet

long enough to cause little distortion at the lower frequencies. It operates at a high temperature, in an evacuated bulb, to minimize the effects of ambient temperature. The effects of ambient temperature are further reduced by winding R108 with wire having a high positive temperature coefficient.

3.1.3 AMPLIFIER.

The amplifier uses four transistors in a single, direct-coupled feedback loop. The input amplifier circuit is chosen for low-noise performance. Transistor Q102 provides a high-impedance drive for the class-B output stage, and achieves a minimum of crossover distortion, yet does not require complicated, temperature-sensitive biasing networks. Negative dc feedback is used in addition to the negative ac feedback to obtain a transfer characteristic which is substantially independent of transistor characteristics, resulting in excellent stability, low distortion, and long-term reliability.

3.2 ACOUSTICAL OUTPUT CIRCUIT.

The output voltage obtained from the oscillator is the same at each frequency. To correct for any variation in establishing the 114 dB sound-pressure level, a potentiometer has been placed in series between the oscillator output and the speaker for each frequency. C107, added at 2000 Hz, forms a series resonant boost circuit with the speaker inductance to insure that all units

will develop the required 114 dB sound-pressure level. This is necessary because the output of the transducer used falls off in response above 1000 Hz.

3.3 ELECTRICAL OUTPUT CIRCUIT.

The oscillator output voltage is also fed to a telephone jack through a resistive divider network (R129, R130, R131, Figure 4-5) which makes available a sinewave of 1 V, rms, $\pm 20\%$, with a source impedance of 6000 Ω .

3.4 BATTERY CHECK CIRCUIT.

The battery checking circuit (Figure 4-5) is a transistor switch. The two transistors, Q106 and Q105, are in the ON state when the battery is above 6 volts. When this condition exists the bulb, P101, will light if the master control is held in the START - BATTERY CHECK position.

CAUTION

Do not hold the switch in the START-CHECK BATTERY position any longer than necessary because the battery will run down very fast.

If the battery voltage drops below 6 volts, the emitter and base voltages of Q106 drop, causing a change in the collector voltage. This change is in the upward direction which will raise the base voltage of Q105,

causing Q105 to go to the OFF state and extinguish P101.

3.5 STARTING CIRCUIT.

Under normal room conditions (23°C and 760 mm of Hg) the oscillator will start and operate properly when the battery connection is made. However, since the output of the oscillator is always connected to the loudspeaker, an annoying, raucous sound will be heard as the thermistor comes up to its proper operating temperature.

At low ambient temperatures the normal oscillator current through the thermistor is not sufficient to warm the thermistor to its proper operating temperature, and the raucous sound will persist, indicating improper operation of the oscillator. To avoid the raucous sound and insure proper starting of the oscillator even at low temperatures, a spring return oscillator START position on the master control is provided. This connects the thermistor in series with the battery and a protective resistor (R132) causing extra warm-up current to be momentarily forced through the thermistor. The warm up takes approximately one second.

SERVICE AND MAINTENANCE

4.1 WARRANTY.



WARRANTY

We warrant that this product is free from defects in material and workmanship and, when properly used, will perform in accordance with GenRad's applicable published specifications. If within one (1) year after original shipment it is found not to meet this standard, it will be repaired or at the option of GenRad, replaced at no charge when returned to a GenRad service facility.

CHANGES IN THE PRODUCT NOT APPROVED BY GENRAD SHALL VOID THIS WARRANTY.

GENRAD SHALL NOT BE LIABLE FOR ANY INDIRECT, SPECIAL OR CONSEQUENTIAL DAMAGES, EVEN IF NOTICE HAS BEEN GIVEN OF THE POSSIBILITY OF SUCH DAMAGES.

THIS WARRANTY IS IN LIEU OF ALL OTHER WARRANTIES, EXPRESS OR IMPLIED, INCLUDING, BUT NOT LIMITED TO, ANY IMPLIED WARRANTY OF MERCHANTABILITY OR FITNESS FOR A PARTICULAR PURPOSE.

4.2 SERVICE.

The warranty stated above attests the quality of material and workmanship in our products. When difficulties do occur, our service engineers will assist in any way possible. If the difficulty cannot be eliminated by the use of the following service instructions, please write or phone our Service Department (see rear cover), giving full information of the trouble and of steps taken to remedy it. Be sure to mention the serial and type number of the instrument.

Before returning an instrument to General Radio for service, please write to our Service Department or nearest Sales Engineering Office, requesting a Returned Material Tag. Use of this tag will ensure proper handling and identification. For instruments not covered by the warranty, a purchase order should be forwarded to avoid unnecessary delay.

4.3 REMOVAL OF THE INSTRUMENT COVER.

To remove the cover;

- a. Remove the round knurled nut (marked OPEN - 1 V 6 kΩ OUT) located approximately half way up the side of the cover,
- b. Slide the cylindrical cover off over the master control.

4.4. MINIMUM PERFORMANCE STANDARDS.

To check the general performance of the Type 1562 Sound-Level Calibrator, proceed as follows:

a. Remove the cover as above and install a good nine volt battery. (See Figure 4-1 for position).

b. Replace the cover and secure it with the knurled nut.

c. Turn the master control dial to START-CHECK BATTERY and observe that the dial light lights, indicating that the battery is good. Release the control and it will return to OFF.

CAUTION

Do not hold the switch in the START - CHECK BATTERY position any longer than necessary because the battery will run down very fast in this switch position.

d. Turn the master control dial to START-CHECK BATTERY and hold for about one second and then turn it to 2000 Hz. After a slight pause a signal of 2000 Hz should be heard from the acoustic coupler end of the instrument.

e. Turn the dial to each of the four remaining frequencies and listen for a tone. This indicates that there is an acoustical output present.

f. Check the electrical output at each frequency by connecting a VTVM, such as the GR Type 1806, through a telephone plug into the output jack (knurled nut marked OPEN - 1 V 6 k Ω OUT) on the side of the instrument. The voltage should be 1.0 V, rms, $\pm 20\%$.

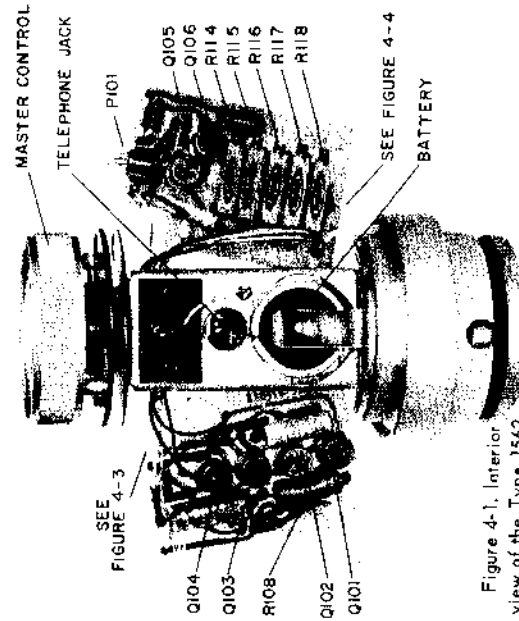

Figure 4-1. Interior view of the Type 1562.

g. Check the accuracy of the output frequency by connecting a digital counter (Type 1192) into the output jack through a telephone plug. The value should be within $\pm 3\%$ of the desired frequency.

h. Insert the 1/2-inch microphone adaptor into the acoustic coupler and see that the ball detents hold it firmly.

i. Repeat step h for the 1-inch adaptor.

4.5 TROUBLE-ANALYSIS.

The following is a list of trouble symptoms and probable solutions:

a. Bulb fails to light in BATTERY CHECK position.

- 1) Low battery.
- 2) Bulb failure.
- 3) Failure of Q105 or Q106

(Table 4-1, Figure 4-1).

b. No acoustical or electrical output at any frequency (BATTERY CHECK working):

- 1) R108 open (Figure 4-1).

c. No acoustical or electrical output at any frequency (BATTERY CHECK working):

1) Failure of Q101, Q102, Q103, or Q104 (Table 4-1, Figure 4-1).

d. Acoustical output not "clean" signal at all frequencies, electrical output high (about 3 volts, rms) (BATTERY CHECK working):

- 1) Thermistor (R133) open.

Table 4-1

Transistor Voltages ¹			
Transistor	Switch Position	Terminal	DC Volts to Ground
Q101	500 Hz	E	4.00
		C	8.20
Q102	500 Hz	E	8.40
		C	4.02
Q103	500 Hz	E	4.04
		C	9.00
Q104	500 Hz	E	4.04
		C	0
Q105	BATTERY CHECK	E	9.00
		B	8.60
		C	8.90
Q106	BATTERY CHECK	E	0.70
		C	1.50 ²

1. Battery voltage in 500 Hz position equals 9.00 V for measurements. Measurements made with Type 1806 VTVM.

2. Varies widely with battery voltage.

e. No acoustical or electrical output at one particular frequency (BATTERY CHECK working):

1) Check Wien-bridge resistors associated with that frequency (for example R123 and R128 for 2 kHz, see Figure 4-5).

2) Check wiring for the particular frequency.

f. No acoustical output at one particular frequency (electrical output and BATTERY CHECK working):

1) Check potentiometer associated with that frequency (R114 through R118, see Figure 4-5).

2) Check wiring associated with that frequency.

g. No acoustical output at any frequency (electrical output and BATTERY CHECK working):

1) Defective transducer (SP101, Figure 4-5).

4.6 REPLACEMENT OF DEFECTIVE PARTS.

If a part is found to be defective in the instrument replace it now and proceed to paragraph 4.7. In replacing a part, the interior view (Figure 4-1), the etched-board diagrams (Figures 4-2, 4-3, 4-4), the schematic diagram (Figure 4-5), and the parts list following this section will be of assistance.

4.7 CALIBRATION CHECK.

To calibrate sound-level-measuring equipment used to check compliance with OSHA or other noise-control legislation, special facilities are required. These facilities must include a standard microphone, such as the Western Electric Co. 640AA, that possesses a known level traceable to the National Bureau of Standards. Such a facility exists at General Radio and was used to establish the calibration of the instrument at the time of manufacture and is available for subsequent calibrations.

APPENDIX

USE OF THE NOMOGRAPH

CORRECTION OF BAROMETRIC PRESSURE TO STATION ALTITUDE.

To obtain a corrected barometric pressure for a station:

- a. Determine the station's altitude above sea level (see chart later in Appendix).
- b. Obtain a barometric pressure reading corrected to sea level from a barometer. (If the barometer reads only values in millimeters, find the corresponding value of millibars from the right-hand scales.
- c. Place a straight-edge across the proper points on the center and left-hand scales of the nomograph, and read the actual pressure at the station, on the right-hand scales.

CONVERSION FROM MILLIMETERS OF MERCURY TO INCHES OF MERCURY.

To convert from millimeters of mercury to inches of mercury proceed as follows:

- a. Find the barometric pressure value in millimeters of mercury on the right-hand scales.
- b. Obtain the corresponding value in millibars from the same scales.
- c. Move to the left-hand scales and find the millibar value obtained in step b.
- d. Read the corresponding value of barometric pressure in inches of mercury from the left-hand scales.

ALTITUDES ABOVE SEA LEVEL FOR SELECTED
CITIES IN U.S. AND CANADA

NOMOGRAPH FOR APPLYING ALTITUDE CORRECTION
TO BAROMETRIC PRESSURE

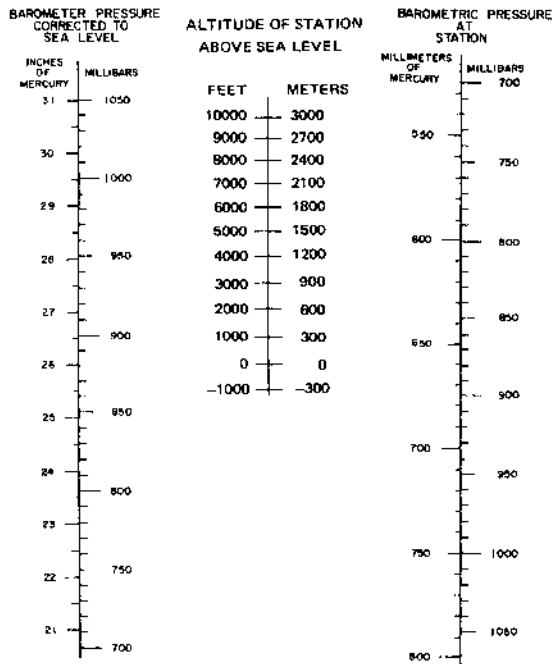

City	Feet Above Sea Level
Akron, Ohio	950
Albany, New York	20
Allentown, Pennsylvania	320
Ashland, Kentucky	530
Atlanta, Georgia	1105
Augusta, Georgia	141
Baltimore, Maryland	81
Bangor, Maine	21
Bay City, Michigan	593
Binghamton, New York	865
Birmingham, Alabama	598
Boise, Idaho	2717
Boston, Massachusetts	45
Brandon, Man.	1204
Buffalo, New York	590
Burlington, Vermont	190
Bridgeport, Connecticut	12
Calgary, Alta.	3439
Cambridge, Massachusetts	80
Camden, New Jersey	30
Campbellton, N.B.	42
Charleston, South Carolina	13
Charlotte, North Carolina	734
Charlottetown, P.E.I.	8
Chicago, Illinois	604
Cleveland, Ohio	600
Colorado Springs, Colorado	6012
Columbus, Georgia	261
Columbus, Ohio	759
Council Bluffs, Iowa	989
Dallas, Texas	437

<i>City</i>	<i>Feet Above Sea Level</i>	<i>City</i>	<i>Feet Above Sea Level</i>
Dartmouth, N.S.	14	London, Ontario	804
Davenport, Iowa	571	Los Angeles, California	292
Dayton, Ohio	743	Louisville, Kentucky	454
Denver, Colorado	5227	Manchester, New Hampshire	210
Des Moines, Iowa	626	Memphis, Tennessee	238
Duluth, Minnesota	626	Miami, Florida	15
Edmonton, Alta.	2183	Milwaukee, Wisconsin	609
Elizabeth, New Jersey	28	Minneapolis, Minnesota	826
Erie, Pennsylvania	709	Mobile, Alabama	15
Evansville, Indiana	380	Moncton, N.B.	50
Flint, Michigan	716	Montgomery, Alabama	191
Fort Smith, Arkansas	445	Montreal, P.Q.	110
Fort Wayne, Indiana	780	Nashville, Tennessee	498
Fort Worth, Texas	600	Newark, New Jersey	43
Fredericton, N.B.	32	New Haven, Connecticut	21
Galveston, Texas	28	New London, Connecticut	27
Grand Rapids, Michigan	628	New Orleans, Louisiana	5
Great Falls, Montana	3309	New York, New York	35
Halifax, N.S.	59	Norfolk, Virginia	38
Hamilton, Ontario	300	Oakland, California	18
Harrisburg, Pennsylvania	355	Omaha, Nebraska	1040
Hartford, Connecticut	36	Ottawa, Ontario	200
Houston, Texas	48	Paterson, New Jersey	117
Huntington, West Virginia	565	Peoria, Illinois	465
Indianapolis, Indiana	749	Philadelphia, Pennsylvania	150
Jackson, Mississippi	286	Phoenix, Arizona	1085
Jacksonville, Florida	25	Pittsburg, Pennsylvania	742
Jersey City, New Jersey	44	Portland, Maine	34
Kansas City, Missouri	750	Portland, Oregon	69
Knoxville, Tennessee	895	Providence, Rhode Island	43
Lansing, Michigan	842	Quebec, P.Q.	20
Lexington, Kentucky	966	Racine, Wisconsin	619
Lincoln, Nebraska	1169	Regina, Sask.	1414
Little Rock, Arkansas	286	Reno, Nevada	4487

City	Feet Above Sea Level
Richmond, Virginia	84
Rochester, New York	509
Saint John, N.B.	21
Saint Louis, Missouri	460
Saint Paul, Minnesota	754
Salt Lake City, Utah	4300
Sacramento, California	30
San Antonio, Texas	657
San Francisco, California	50
Saskatoon, Sask.	1596
Savannah, Georgia	42
Scranton, Pennsylvania	757
Seattle, Washington	51
Shreveport, Louisiana	217
Sioux Falls, South Dakota	1405
South Bend, Indiana	718
Spokane, Washington	1905
Springfield, Massachusetts	101
Sydney, N.S.	10
Syracuse, New York	410
Tacoma, Washington	87
Toledo, Ohio	594
Toronto, Ontario	250
Topeka, Kansas	909
Tucson, Arizona	2382
Tulsa, Oklahoma	700
Utica, New York	448
Vancouver, B.C.	18
Washington, D.C.	100
Wichita, Kansas	1285
Windsor, Ontario	580
Winnipeg, Man.	727
Youngstown, Ohio	832

ALTITUDES ABOVE SEA LEVEL FOR SELECTED FOREIGN CITIES

City	Altitude Above Sea Level	
	Meters	Feet
Adelaide, Australia	11	35
Amman, Jordan	665	2400
Amsterdam, Netherlands	50	16
Ankara, Turkey	640	2250
Athens, Greece	92	300
Belgrade, Yugoslavia	138	450
Berlin, Germany	35	115
Bombay, India	8	25
Brussels, Belgium	58	190
Buenos Aires, Argentina	14	45
Cairo, Egypt	30	98
Canberra, Australia	900	2000
Copenhagen, Denmark	76	25
Johannesburg, U.S. Africa	1750	5689
Lahore, Pakistan	210	706
La Paz, Bolivia	3700	12200
London, England	74	245
Manila, Philippines	8	25
Melbourne, Australia	10	30
Mexico City, Mexico	2200	7349
Munich, Germany	510	1700
Paris, France	42	300
Prague, Czech.	175	575
Rome, Italy	28	95
Santiago, Chile	550	1800
San Paulo, Brazil	820	2700
Seoul, Korea	78	250
Stockholm, Sweden	11	35
Tokyo, Japan	10	30
Warsaw, Poland	73	240
Zurich, Switzerland	400	1360

FEDERAL SUPPLY CODE FOR MANUFACTURERS
 UNITED STATES AND CANADA
 DEFENSE LOGISTICS AGENCY MICROCHIEF
 H4-1 SB 708-41 GSM-FSSHA-1

FMC	MANUFACTURER
01295	TEXAS INSTRUMENTS, DALLAS, TX 75222
09823	SURGESS INC., FREEPORT, IL 61032
14433	TI SEMICONDUCTORS, W. PALM BEACH, FL 33402
15801	FERNAL ELECTRONICS, FRAMINGHAM, MA 01701
24855	GENRAD, CONCORD, MA 01742
56289	SPRAGUE ELECTRIC, NORTH ADAMS, MA 01247
71744	CHICAGO MINIATURE LAMP, CHICAGO, IL 60640
75042	TRC, BURLINGTON, IA 52601
90294	BOURNS LABORATORIES, RIVERSIDE, CA 92506
81349	MILITARY SPECIFICATIONS
83255	PARKER SEAL, CULVER CITY, CA 90231
94322	TTL LABS., MANCHESTER, NH 03103

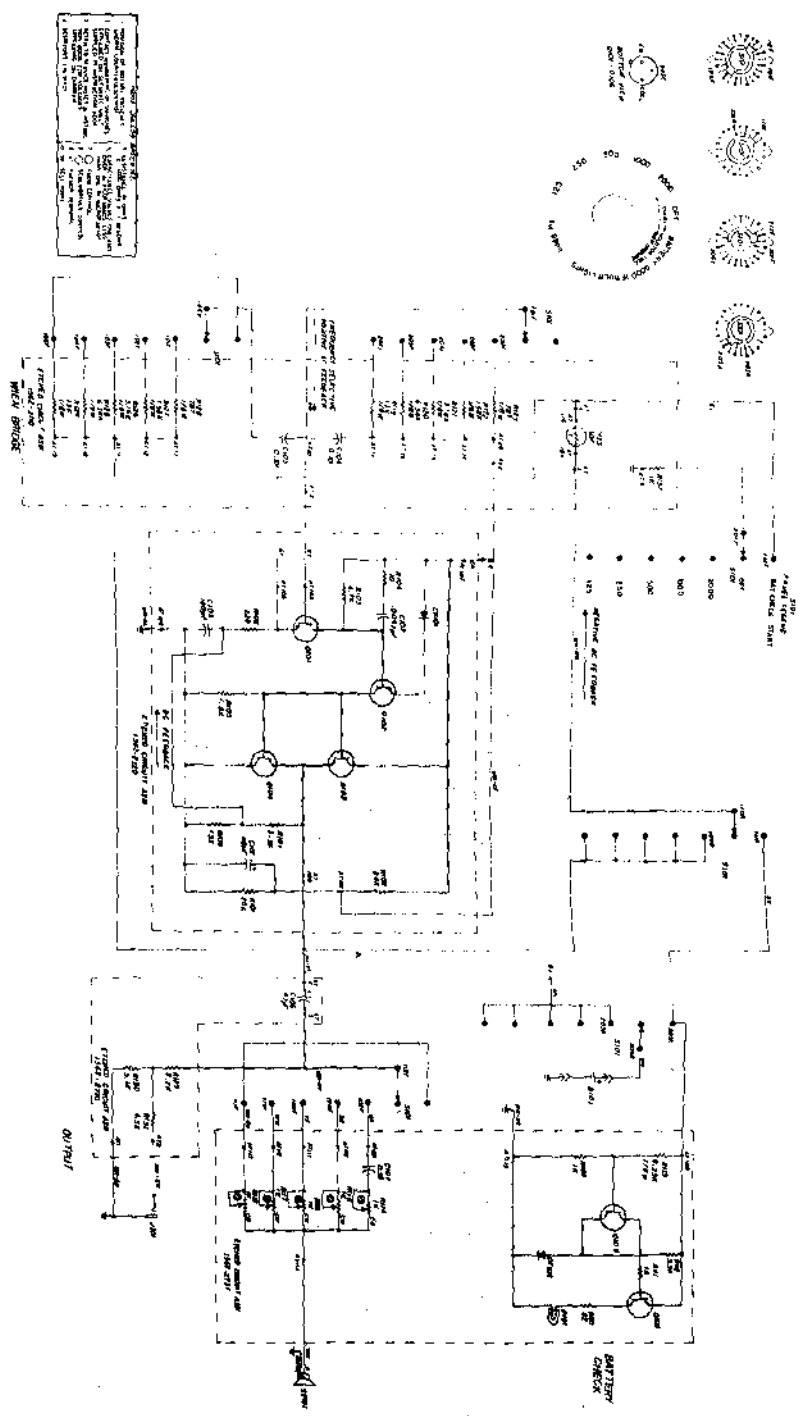

Figure 4-5. Schematic diagram for Type 1562-A Sound-Level Calibrator.

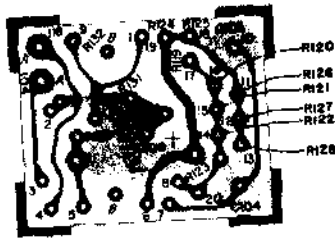

Figure 4-2. Wien-Bridge and Electrical-Output etched-circuit assembly. (For complete etched-circuit board assembly, order Part Number 1562-2710.)

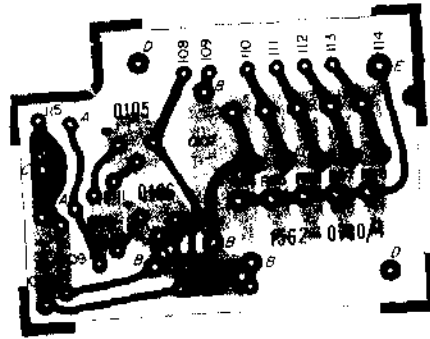

Figure 4-4. Acoustical-Output and Battery-Check etched-circuit assembly. (For complete etched-circuit assembly, order Part Number 1562-2731.)

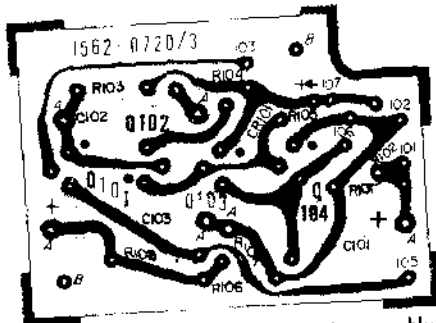

Figure 4-3. Amplifier etched-circuit assembly. (For complete etched-circuit assembly, order Part Number 1562-2720.)

NOTE: The number on the foil side is not the part number for the complete assembly. The dot on the foil at the transistor socket indicates the collector lead.

ELECTRICAL PARTS LIST

REF DES	DESCRIPTION	PART NO.	FMC	MFR	PART NUMBER
<u>WFTN-AMPLIFIER & ELECTRICAL-OUTPUT PC BOARD P/N 1562-2710</u>					
C 104	CAP MYLAR .100UF 1 PCT 100V	4860-7932	56289	410P	0.101 UF 1PCT
C 105	CAP MYLAR .100UF 1 PCT 100V	4860-7932	56289	410P	0.101 UF 1PCT
C 106	CAP TANT .47 UF 20PCT 6V	4450-5500	56289	1500476X0006R2	
R 117	RES FLM 15.0K 1 PCT 1/8W	6250-2130	81349	AN5501302F	
R 120	RES FLM 6.39K 1 PCT 1/8W	6250-1634	81349	AN5506341F	
R 121	RES FLM 3.16K 1 PCT 1/8W	6250-1316	81349	AN5503161F	
R 122	RES FLM 1.58K 1 PCT 1/8W	6250-1158	81349	AN5501581F	
R 123	RES FLM 7.57 OHM 1 PCT 1/8W	6250-0787	81349	AN5507870F	
R 124	RES FLM 15.0K 1 PCT 1/8W	6250-2130	81349	AN5501302F	
R 125	RES FLM 6.39K 1 PCT 1/8W	6250-1634	81349	AN5506341F	
R 126	RES FLM 3.16K 1 PCT 1/8W	6250-1316	81349	AN5503161F	
R 127	RES FLM 1.58K 1 PCT 1/8W	6250-1158	81349	AN5501581F	
R 128	RES FLM 7.57 OHM 1 PCT 1/8W	6250-0787	81349	AN5507870F	
R 129	RES COMP 2.7 K 5PCT 1/4W	6099-2275	81349	RCR076272J	
R 130	RES COMP 5.1 K 5PCT 1/4W	6099-2515	81349	RCR075512J	
R 131	RES COMP 4.3 K 5PCT 1/4W	6099-2435	81349	RCR076432J	
R 132	RES COMP 1.0 K 5PCT 1/4W	6099-2105	81349	RCR076102J	

<u>AMPLIFIER PC BOARD P/N 1562-2720</u>					
C 101	CAP ALUM 60 UF 6V	4450-3600	56289	30D406G006	
C 102	CAP MYLAR .2047UF 10 PCT 600V	4860-7400	75742	6630W .0047 UF 10PCT	
C 103	CAP TANT 180 UF 20PCT 6V	4450-5617	56289	150D187X0006R2	
CR 104	DIODE RECTIFIER 1N645	6082-1016	14433	1N645	
Q 101	TRANSISTOR 2N1304	8210-1304	01295	2N1304	
Q 102	TRANSISTOR 2N1305	8210-1305	01295	2N1305	
Q 103	TRANSISTOR 2N1304	8210-1304	01295	2N1304	
Q 104	TRANSISTOR 2N1305	8210-1305	01295	2N1305	
R 101	RES COMP 20 K OHM 5PCT 1/4W	6099-3205	81349	RCR076203J	
R 102	RES COMP 24 K OHM 5PCT 1/4W	6099-3245	81349	RCR076243J	
R 103	RES COMP 4.7 K 5PCT 1/4W	6099-2475	81349	RCR076472J	
R 104	RES COMP 10 OHM 5PCT 1/4W	6099-0105	81349	RCR076100J	
R 105	RES COMP 1.2 K 5PCT 1/4W	6099-2195	81349	RCR076182J	
R 106	RES COMP 13 K OHM 5PCT 1/4W	6099-3135	81349	RCR076133J	
R 107	RES COMP 3.9 K 5PCT 1/4W	6099-2395	81349	RCR076392J	
R 108	RES W 220 OHM 3 PCT 1/500 TC	6670-1040	94322	5A-71 220 OHM 3PCT	

<u>ACOUSTICAL-OUTPUT & BATTERY-CHECK PC BOARD P/N 1562-2731</u>					
C 107	CAP MYLAR METAL 0.39UF 10PCT 50V	4860-9702	56289	431P3949R5	
CR 102	DIODE RECTIFIER 1N645	6082-1016	14433	1N645	
Q 105	TRANSISTOR 2N1305	8210-1305	01295	2N1305	
Q 106	TRANSISTOR 2N1304	8210-1304	01295	2N1304	
R 109	RES COMP 1.0 K 5PCT 1/4W	6099-2105	81349	RCR076102J	
R 110	RES COMP 67 OHM 5PCT 1/4W	6099-0625	81349	RCR076620J	
R 111	RES COMP 1.0 K 5PCT 1/4W	6099-2105	81349	RCR076102J	
R 112	RES COMP 4.3 K 5PCT 1/4W	6099-2435	81349	RCR076432J	
R 113	RES FLM 6.25K 1 PCT 1/8W	6250-1825	81349	AN5508251F	
R 114	POT W 1K4 1K OHM 10 PCT 20T	6051-2109	80294	3005P-1-102	
R 115	POT W 10K 1K OHM 10 PCT 20T	6051-2109	80294	3005P-1-102	
R 116	POT W 10K 1K OHM 10 PCT 20T	6051-2109	80294	3005P-1-102	
R 117	POT W 10K 1K OHM 10 PCT 20T	6051-2109	80294	3005P-1-102	
R 118	POT W 10K 1K OHM 10 PCT 20T	6051-2109	80294	3005P-1-102	

<u>CHASSIS MOUNTED PARTS P/N 1562-3000</u>					
B 101	BATTERY 6V CARBON ZINC 1600	9410-3000	09873	P6	
P 102	LAMP FLANGE BASE 6V .094 1000OH	5600-0316	71744	CM-345	
K 133	THERMISTOR 40K OHM 20PCT	6740-1400	15801	BA-44V3	
S 101	SWITCH ROTARY ASM	7890-4330	24655	7890-4330	
SP 101	CONTROLLED MAGNETIC TRANSDUCER	1567-0410	24655	1567-0410	

MECHANICAL PARTS LIST					
QNT	DESCRIPTION	PART NO.	FMC	MFR	PART NUMBER
1	DIAL ASM	1562-2030	24655	1562-2030	
1	COVER	1562-6080	24655	1562-6080	
1	BUSHING	1562-6091	24655	1562-6091	
1	O RING	5855-1437	83289	2-221	
1	CARRYING CASE	1562-0430	24655	1562-0430	

CERTIFIED
INDUSTRIAL SOUND LEVEL METER SET
IN ACCORDANCE WITH 42 CFR 82



NATIONAL INSTITUTE
FOR OCCUPATIONAL SAFETY AND HEALTH

Certificate No. TC-51-114 Issued to
Certified
Concord, Mass., U.S.A.

The certified set consists of the following parts:

Description	Part No.
Model 1565-B Sound Level Meter	1565-9702
Microphone	1560-2133
Model 1562 or Model 1567 Sound Level Calibrator	1562-9701, or 1567-9701
Windscreen (Optional)	1560-9521
Instruction Manuals	1565-0101, 1562-0100, 1567-0100

LIMITATIONS

The Model 1565-B sound level meter is certified by NIOSH for occupational noise measurements only when calibrated according to the instruction manual on the day of use before and after a sound level measurement period by a Model 1562 or Model 1567 sound level calibrator. Certification of the sound level meter applies only to use of the A-weighting network and the slow response meter characteristic.

Model 1565-B Sound Level Meter Microphone Configurations not Certified by NIOSH: Model 1565-B (1565-9702) sound level meter with ceramic microphone cartridge (1560-2133), microphone extension cable (1560-9573), and with or without windscreen (1560-9521).