

100 copies printed
June 9, 1937
Sp. - Mass.

GENERAL RADIO COMPANY
CAMBRIDGE, MASSACHUSETTS, U. S. A.

OPERATING INSTRUCTIONS
FOR
TYPE 614-A
SELECTIVE AMPLIFIER

PART 1
DESCRIPTION

PURPOSE The Type 614-A Selective Amplifier is designed for producing and selecting the first ten harmonics of a 1000-cycle voltage applied to its input terminals. The instrument is particularly useful in connection with the Class C-21-H Primary Frequency Standard as it permits comparisons to be made at each multiple of 1 kc with the same accuracy as that of the primary standard. The instrument is also useful in connection with calibrations made with a cathode-ray oscillograph.

PRINCIPLE OF OPERATION The applied 1-kc voltage is impressed on a harmonic-producing tube. The

output circuit of this tube is provided with ten fixed tuned circuits, any one of which may be placed in circuit by means of the SELECTOR switch. A stage of amplification follows the tuned circuits, arranged so as to provide regeneration for sharpening the tuning. An output amplifier, with an output meter, not only raises the level of the output, but provides for essentially isolating the regenerative tube from effects of changes in load impedance.

POWER SUPPLY The Type 614-A Selective Amplifier is completely a-c operated from 115-volt 50-60 cycle mains.

PART 2
INSTALLATION

CONNECTIONS Connections for the 115-volt 50-60 cycle supply should be made through the motor-attachment plug provided for the purpose. The 1-kc input and the harmonic output terminals are available on the front panel for temporary connections; these also appear on the multipoint connector at the rear of the instrument for permanent connections.

VACUUM TUBES

Install as follows:

<u>Type</u>	<u>Location (Seen from rear)</u>
82	Left socket (4-prong)
56	3 Right sockets (5-prong)

PART 3
OPERATION

Throw the FIL-PLATE switch to "ON". The panel bull's-eye should light, showing that power is on. Set SELECTOR switch on the point corresponding to the multiple of 1 kc desired. Set output meter shunt at maximum (to right). Advance input control from minimum (at left) until a reading is obtained on output meter. Next advance regeneration control toward the right, reducing the input, if necessary, until the point of oscillation is almost reached. If these instructions are followed, the maximum output, consistent with the best waveform, will be obtained.

Where the best waveform is not required, considerably more output may be ob-

tained by advancing the input control or the regeneration control, or both, for maximum output voltage. If the output voltage exceeds the range of the meter, move the meter shunt toward the left.

The presence of beats on the meter, or an abnormally high output meter reading, are indications that the amplifier is oscillating and that the regeneration should be reduced by moving the regeneration control to the left.

Some readjustment of both input control and regeneration control will be required for each setting of the SELECTOR switch.

GENERAL RADIO COMPANY

PART 4 SPECIFICATIONS

Frequency Range: Each multiple of 1 kc from 1 to 10 inclusive.

Power Supply: 115 volts, 50-60 cycles.

Power Input: 25 watts.

Controls: Power supply ON-OFF switch; input voltage control; regeneration control; output meter shunt; harmonic selector switch.

Meters: Output meter.

Tubes: Supplied with instrument.

1 - 82 Rectifier
3 - 56 Amplifiers

Mounting: Standard 19-inch relay-rack mounting. Unit fitted with dust cover.

Accessories Supplied: See packing list.

Additional Accessories Required: None.

Dimensions: Panel (width) 19 x (height) 8-3/4 x (depth) 11 inches, over-all.

Net Weight: 38 pounds.

VACUUM-TUBE DATA

These data were measured on a stock model of the Type 614-A Selective Amplifier using a Weston Model 772 Analyzer. Where operating voltages and currents are

obviously not critical, variations of as much as 20% from these values may be expected.

Type 614-A Selective Amplifier*

Tube	Function	Filament (60~)	Plate to Cathode	Plate Current	Grid Bias
T1		2.5 volts	135 volts	3.5 ma	-7 volts
T2		2.5 volts	180 volts	5.5 ma	-8.5 volts
T3		2.5 volts	150 volts	2.3 ma	-9.0 volts
T4	Rectifier†	2.5 volts	175 volts (60~)	-	-

*No signal input. Regeneration control at zero.

†D-C output (cathode-to-ground) = 200 volts.

PATENT NOTICE

This instrument is manufactured under the following U. S. Patents and license agreements:

Patents of the American Telephone and Telegraph Company, solely for utilization in research, investigation, measurement, testing, instruction and development work in pure and applied science.

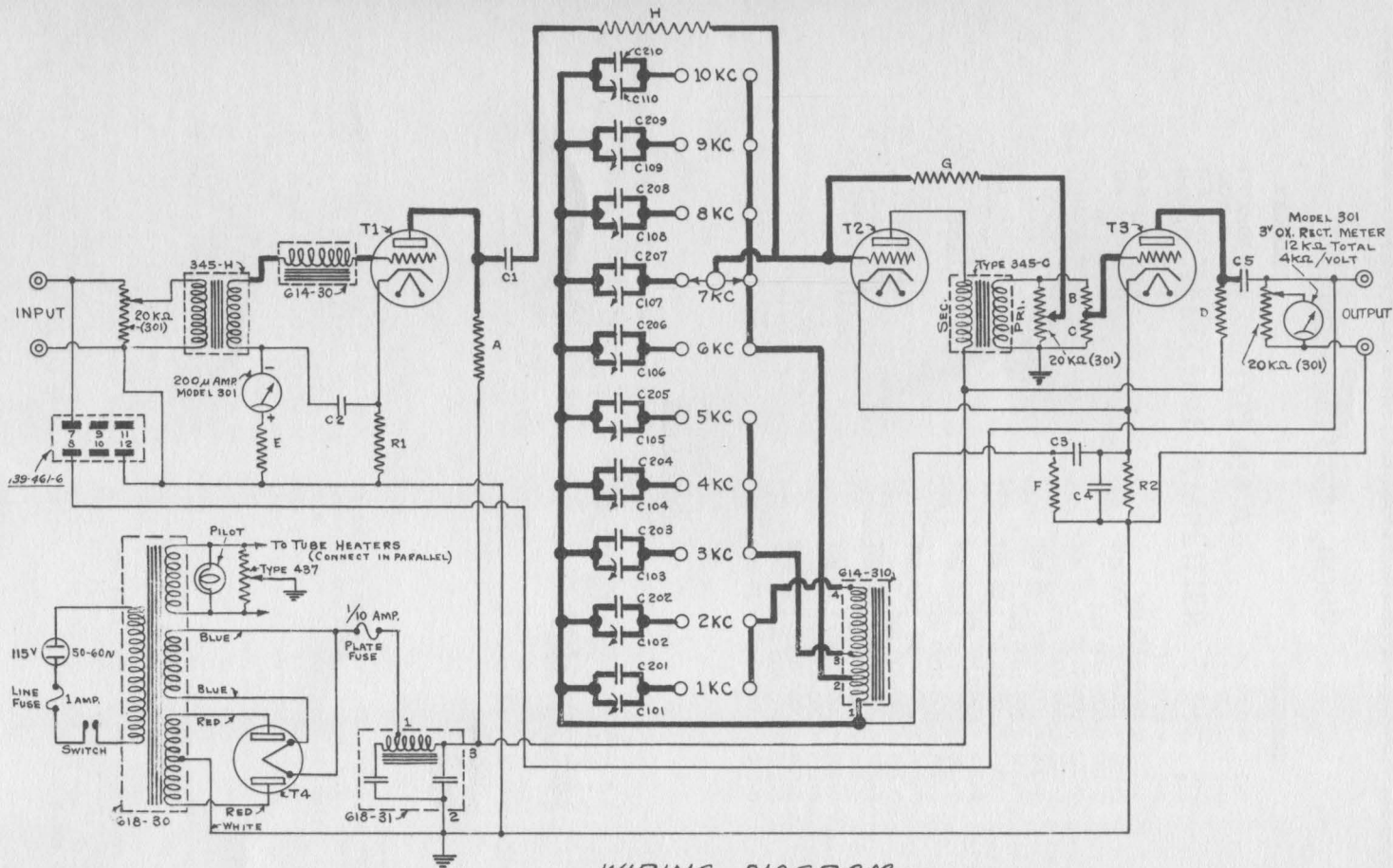

WIRING DIAGRAM
OF
G14-A SELECTIVE AMPLIFIER

GENERAL RADIO COMPANY

PARTS LIST

Condensers

C-1	=	0.01	μf
C-2	=	1.0	μf
C-3	=	1.0	μf
C-4	=	1.0	μf
C-5	=	0.05	μf
C-101	=	1000-3000	μμf
C-201	=	.0140	μf + 100 μμf
C-102	=	500-1000	μμf
C-202	=	.00325	μf + 25 μμf
C-103	=	500-1000	μμf
C-203	=	.00500	μf + 25 μμf
C-104	=	500-1000	μμf
C-204	=	.00245	μf + 25 μμf
C-105	=	200-500	μμf
C-205	=	.00165	μf + 15 μμf
C-106	=	500-1000	μμf
C-206	=	.00205	μf + 25 μμf
C-107	=	200-500	μμf
C-207	=	.00150	μf + 15 μμf
C-108	=	200-500	μμf
C-208	=	.00095	μf + 15 μμf
C-109	=	200-500	μμf
C-209	=	.00060	μf + 15 μμf
C-110	=	200-500	μμf
C-210	=	.00030	μf + 15 μμf

Resistors

A	=	20,000	Ω
B	=	50,000	Ω
C	=	15,000	Ω
D	=	20,000	Ω
E	=	10,000	Ω
F	=	50,000	Ω
G	=	0.25	MΩ
H	=	2	MΩ
R1	=	2000	Ω
R2	=	1200	Ω

Tubes

T1	=	RCA-56
T2	=	RCA-56
T3	=	RCA-56
T4	=	RCA-82

PACKING LIST

1 - Attachment cord and plug	2 - Pilot lamps (2.5 volt)
1 - Multipoint connector	1 - 82 Rectifier
5 - 0.1-ampere fuses	3 - 56 Amplifiers
5 - 1-ampere fuses	