

**SR-100 / SR-100DC**  
**SR-102 / SR-102DC**  
**SR-103 / SR-103DC**  
**SR-104 / SR-104DC**



Copyright © 2014 IET Labs, Inc.  
Visit [www.ietlabs.com](http://www.ietlabs.com) for manual revision updates

SR Series im/July 2014

◆ PRECISION INSTRUMENTS FOR TEST AND MEASUREMENT ◆



[www.ietlabs.com](http://www.ietlabs.com)  
Email: [info@ietlabs.com](mailto:info@ietlabs.com)  
TEL: (516) 334-5959 • FAX: (516) 334-5988

## **WARRANTY**

We warrant that this product is free from defects in material and workmanship and, when properly used, will perform in accordance with applicable IET specifications. If within one year after original shipment, it is found not to meet this standard, it will be repaired or, at the option of IET, replaced at no charge when returned to IET. Changes in this product not approved by IET or application of voltages or currents greater than those allowed by the specifications shall void this warranty. IET shall not be liable for any indirect, special, or consequential damages, even if notice has been given to the possibility of such damages.

THIS WARRANTY IS IN LIEU OF ALL OTHER WARRANTIES, EXPRESSED OR IMPLIED, INCLUDING BUT NOT LIMITED TO, ANY IMPLIED WARRANTY OF MERCHANTABILITY OR FITNESS FOR ANY PARTICULAR PURPOSE.



## WARNING



OBSERVE ALL SAFETY RULES  
WHEN WORKING WITH HIGH VOLTAGES OR LINE VOLTAGES.

**Dangerous voltages may be present inside this instrument. Do not open the case  
Refer servicing to qualified personnel**

### **HIGH VOLTAGES MAY BE PRESENT AT THE TERMINALS OF THIS INSTRUMENT**

WHENEVER HAZARDOUS VOLTAGES (> 45 V) ARE USED, TAKE ALL MEASURES TO  
AVOID ACCIDENTAL CONTACT WITH ANY LIVE COMPONENTS.

USE MAXIMUM INSULATION AND MINIMIZE THE USE OF BARE  
CONDUCTORS WHEN USING THIS INSTRUMENT.

**Use extreme caution when working with bare conductors or bus bars.**

WHEN WORKING WITH HIGH VOLTAGES, POST WARNING SIGNS AND  
KEEP UNREQUIRED PERSONNEL SAFELY AWAY.



## CAUTION



DO NOT APPLY ANY VOLTAGES OR CURRENTS TO THE TERMINALS OF THIS  
INSTRUMENT IN EXCESS OF THE MAXIMUM LIMITS INDICATED ON  
THE FRONT PANEL OR THE OPERATING GUIDE LABEL.

# Contents

<b>Chapter 1 Introduction .....</b>	<b>1</b>
1.1 Introduction.....	1
1.2 Deleted Case (DC) option.....	2
<b>Chapter 2 Specifications .....</b>	<b>3</b>
Specifications .....	3
<b>Chapter 3 Operation .....</b>	<b>6</b>
3.1 Self-Heating .....	6
3.2 Temperature compensation .....	6
3.2.1 Temperature sensor.....	6
3.2.2 Connection to the temperature sensor.....	6
3.2.3 Calculating the correction.....	7
3.3 Schematic Layouts.....	8
3.4 Calibrating secondary Resistance Standards .....	8
3.5 Bridge connections.....	9
3.5.1 Wheatstone Bridge.....	9
3.5.2 Kelvin Bridges.....	10

## Figures and Tables

<i>Figure 1-1: SR Series Transportable Resistance Standard .....</i>	<i>1</i>
<i>Figure 2-1: Temperature coefficient comparison .....</i>	<i>4</i>
<i>Figure 2-2: Typical Operating Guide affixed to unit.....</i>	<i>5</i>
<i>Table 3-1: Voltage and power limits .....</i>	<i>6</i>
<i>Figure 3-1: Sample temperature correction chart .....</i>	<i>7</i>
<i>Figure 3-2: SR-100 schematic diagram for test connections.....</i>	<i>8</i>
<i>Figure 3-3: SR-102 schematic diagram for test connections.....</i>	<i>8</i>
<i>Figure 3-4: SR-103 schematic diagram for test connections.....</i>	<i>8</i>
<i>Figure 3-5: SR-104 schematic diagram for test connections.....</i>	<i>8</i>
<i>Figure 3-6: Wheatstone bridge connections.....</i>	<i>9</i>
<i>Figure 3-7: Kelvin bridge connections .....</i>	<i>10</i>
<i>Figure 3-8: Model 242D Resistance-Measuring System Connection.....</i>	<i>10</i>

# Chapter 1

## INTRODUCTION

### 1.1 Introduction

The SR-100, SR-102, SR-103, and SR-104 Series of Transportable Resistance Standards are at a performance grade just under national laboratory standards. They are 1  $\Omega$ , 100  $\Omega$ , 1 k $\Omega$ , and 10 k $\Omega$  resistance standards that have historically been shown to be pre-eminent in accuracy, stability, and temperature coefficient performance. See Figure 1-1.



**Figure 1-1: SR Series Transportable Resistance Standard**

The SR Series offer an extremely low temperature coefficient of less than 0.1 ppm/ $^{\circ}$ C, and power coefficient of less than 1 ppm/W. These characteristics facilitate precise laboratory comparisons without critical environmental controls.

For maximum accuracy, these standards offer a temperature-correction chart and a built-in RTD temperature sensor to determine internal temperature and make a precise correction.

These resistance standards are designed as totally transportable bench top instruments. They are protected against shock caused by temperature and pressure gradients because they are sealed in a mechanically reinforced, oil-filled container. This makes it possible for these standards to be transported from one region to another or through varying altitudes.

To eliminate lead-resistance, contact-resistance, and leakage-resistance effects, all versions have a five-terminal resistor configuration. The four resistor terminals are gold-plated tellurium-copper. This allows five-terminal measurements that further reduce external resistance.

Accurate resistance levels ranging from 0.1  $\Omega$  to 100 M $\Omega$  can be established using a combination of the SR Series resistance standard, a transfer bridge, and transfer standards such as IET's SR-1010, SR-1030, SR-1050, and SR-1060.

**1.2 Deleted Case (DC) option**  
(SR-100/DC, SR-102/DC, SR-103/DC, SR-103/  
DC)

The deleted case (DC) option can further enhance the stability of the resistance standard. It is specifically designed for oil-bath operation. This version comes without the external case, but it retains the five-terminal connection to the resistor.

When the standards are used in an oil bath, the resistance elements maintain a constant temperature, providing outstanding short-term stability, which is especially important when making Quantum Hall Effect measurements.



## Chapter 2

# SPECIFICATIONS

For the convenience of the user, pertinent specifications are given in a typical **OPERATING GUIDE** affixed to the case of the instrument, such as the one shown in Figure 2-2.

### SPECIFICATIONS

Value	Model Number
1 $\Omega$	SR100
100 $\Omega$	SR102
1,000 $\Omega$	SR103
10,000 $\Omega$	SR104

#### Stability (SR102, 103, 104)

First 2 years:  $\pm 1$  ppm/year

Thereafter:  $\pm 0.5$  ppm/year

#### Temperature coefficient

Temperature coefficient ( $\alpha$ ):

$< 0.1$  ppm/ $^{\circ}\text{C}$  at  $23^{\circ}\text{C}$

1/2 rate of TC change ( $\beta$ ):

$< 0.03$  ppm/ $^{\circ}\text{C}$  from  $18^{\circ}\text{C}$  to  $28^{\circ}\text{C}$

$\alpha$  and  $\beta$  are determined by the following expression:

$$R_s = R_{23} [1 + \alpha_{23}(t-23) + \beta(t-23)^2]$$

where  $R_s$  = Standard Resistance at temperature  $t$

No ovens or external power required

#### Power coefficient

$< 1$  ppm/W

#### Adjustment to nominal

Model	Adjustment to nominal
SR100	$\pm 10$ ppm
SR102, 103, 104	$\pm 1$ ppm

#### Max voltage

500 V peak to case

#### Power rating

1 W (Momentary 100 W overloads will not cause failure)

#### Insulation resistance

All terminals maintain a minimum  $10^{12} \Omega$  to ground

#### Internal temperature sensor

100  $\Omega$ , 1 k  $\Omega$ , or 10 k  $\Omega$  resistor with 1,000 ppm/ $^{\circ}\text{C}$  temperature coefficient.

Integral thermometer well is provided for calibration

#### Hermetic sealing

To eliminate the effects of humidity, the resistor is hermetically sealed in oil with metal-to-glass seals. The resistance changes  $< \pm 0.1$  ppm with normal atmospheric pressure and humidity changes.

#### Pressure effects

No pressure effects under normal atmospheric changes. As an actual historical case, measurements taken at NIST in Gaithersburg, MD (sea-level) will be consistent with measurements taken at NIST in Boulder, CO (1,600 m above sea-level).

#### Connection terminals

Five-terminal construction, four-terminal resistor with ground intercept for the standard and temperature resistor.

#### Thermal emf

Thermal emf at the terminals does not exceed  $\pm 0.1 \mu\text{V}$  under normal conditions.

#### Thermal lagging

Thermal lagging time constant is 1 hour minimum (1-1/e of total change in one hour).

**Dielectric soakage effect**

The resistance stabilizes to within 0.1 ppm of final value within 5 seconds with 1 V applied to the resistor.

**Current reversal**

With the reversal of the current through the resistor, the resistance value changes less than  $\pm 0.1$  ppm.

**Packaging**

The units are mounted in a sturdy formica-veneered wooden case which has a removable lid with a carrying handle. Calibration and other data is attached to the inside of the lid.

**Typical performance:**

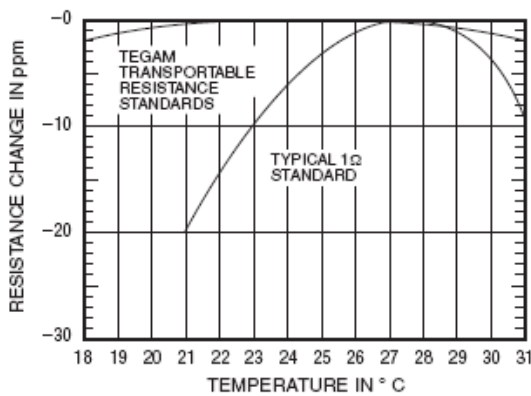

**Figure 2-1: Temperature coefficient comparison between a typical SR-102 unit and a typical 100 Ω resistance standard**

**Shock effects**

The resistance changes is  $< 0.2$  ppm when subjected to 2 drops three-foot drops to a concrete floor on each of the 3 mutually perpendicular faces (6 drops total).

**Dimensions**

**Regular**

25.4 cm x 20.6 cm x 31.1 cm (10" x 8.1" x 12.25")

**Deleted case (DC) version**

12.7 cm x 8.9 cm x 17.8 cm (5.0" x 3.5" x 7.0")

**Weight**

**Regular**

4.8 kg (10.5 lb)

**Deleted case (DC) version**

1.8 kg (4.0 lb)

**Each unit includes:**

- Built-in temperature sensor
- Temperature correction chart
- Instruction manual
- A2LA accredited ISO/IEC17025 calibration certificate

# SR104 RESISTANCE STANDARD

CONSULT INSTRUCTION MANUAL FOR PROPER INSTRUMENT OPERATION



**Nominal Value:** 10 kΩ.  
**Power Rating:** 1 W; momentary 100 W overloads will not cause failure.  
**Stability:** ±1 ppm/ year, first 2 years.  
 ± 0.5 ppm/year thereafter.  
**Breakdown Voltage:** 500 V peak to case.  
**Power Coefficient:** <1 ppm/W

For corrected resistance at other temperatures, see chart or graph or calculate as follows:  
 $R_s = R_{23} [ 1 + \alpha_{23}(t-23) + \beta(t-23)^2 ]$

Where  $R_s$  = Standard Resistance at temperature t  
 $R_{23}$  (resistance at 23.0 °C) = **10.000 001 4 kΩ**  
 (Dev. from nominal value = **0.14 ppm** at 23.0 °C)  
 $\alpha_{23} = \mathbf{0.1 ppm/°C}$      $\beta = \mathbf{-0.026 ppm/°C^2}$

T = Actual temperature as determined by well thermometer or from Temperature Sensor measured resistance ( $R_t$ )

$$T = \left( \frac{R_t - R_{T23}}{R_{T23}} \times 10^3 + 23 \right) ^\circ C$$

Where  $R_t$  is the resistance of Temperature Sensor at temperature T

$R_{T23}$  (sensor resistance at 23.0 °C) = **10.000 10 kΩ**  
 (Deviation from nominal value = **+0.001%** at 23.0 °C)

**Model:** SR-104    **SN:** J1-0824603  
**By:** JOS    **Date:** 16-Oct-2008



Observe all safety rules when working with high voltages or line voltages. Connect the (G) terminal to earth ground in order to maintain the case at a safe voltage. When ever hazardous voltages (>45 V) are used, take all measures to avoid accidental contact with any live components:  
 a) Use maximum insulation and minimize the use of bare conductors. b) Remove power when adjusting switches. c) Post warning signs and keep persons safely away.



formerly manufactured by **esi**

**IET LABS, INC.**  
 CAGE CODE: 62015

534 Main Street, Westbury, NY 11590  
 (800) 475-1211 • (516) 334-5959 • Fax: (516) 334-5988  
[www.ietlabs.com](http://www.ietlabs.com)

SR104-Label100%/05-28-10

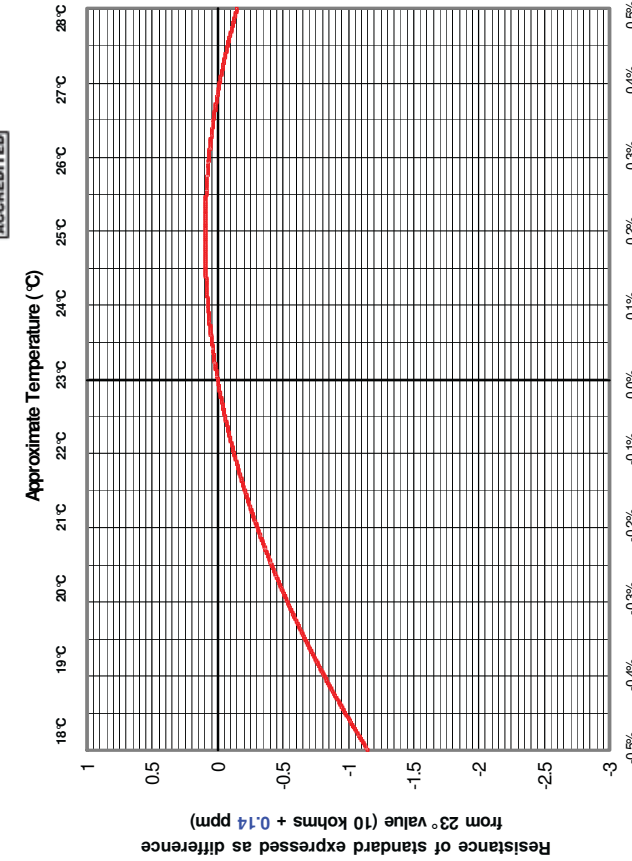

Temperature of standard resistor expressed as percentage change of Temperature Sensor Resistance ( $R_t$ ) at temperature T from ( $R_{T23}$ ) **10.000 10 kΩ**.  
 e.g. if  $R_t = 10.010 1$  is 0.1% above  $R_{T23}$ , the resistance of the standard = **10.010 10 kΩ**.  
 (may also be obtained from the formula or the temperature chart)



**WARNING**

Figure 2-2: Typical Operating Guide affixed to unit

## Chapter 3

# OPERATION

### 3.1 Self-Heating



**To get accurate readings, keep the power low to avoid overheating the instrument. See instructions below.**

To minimize self-heating in the bridge or resistor being measured, low power must be used in both the resistance and temperature sensors. Self-heating is generally noticeable by a steady drift in the reading while power is being applied. It can be avoided if power is kept below 10 mW in the standard and 100 mW in the temperature sensor. Voltage and power limits are given in Table 3-1.

Model	Value	Resistance R		Sensor R	
		Max Voltage	Max Power	Max Voltage	Max Power
SR-100	1 $\Omega$	0.1 V	10 mW	0.1 V	100 mW
SR-102	100 $\Omega$	1 V	10 mW	0.1 V	100 mW
SR-103	1 k $\Omega$	3.16 V	10 mW	10 V	100 mW
SR-104	10 k $\Omega$	10 V	10 mW	1 V	100 mW

**Table 3-1: Voltage and power limits**

### 3.2 Temperature compensation

#### 3.2.1 Temperature sensor

The temperature sensor resistance network consists of a copper resistor in series with a low temperature coefficient resistor. The resistance of the network at 23°C has a temperature coefficient of 1,000 ppm (0.1%) per °C.

The temperature sensor is mounted in the same oil-filled container as the standard resistor, and thus is at the same temperature. Since the standard resistor and the temperature sensor have the same nominal resistance, they can be measured on the same bridge and at the same settings.

#### 3.2.2 Connection to the temperature sensor

The temperature sensor can be connected to the same bridges in the same manner as the standard resistor. The bridge can be the same one used to measure the standard resistor, but generally the accuracy does not need to be as high.

### 3.2.3 Calculating the temperature correction

The temperature correction chart (in the lid of the unit) can be used to correct the resistance of the Transportable Standard Resistor for temperature effects. Figure 3-1 is a sample of the calibration data and correction chart attached to the unit.

The precise 23°C value of the standard is given in location (1). In the example shown in Figure 3-1, the standard resistance is:

$$R_{23} \text{ (resistance at } 23.0 \text{ }^\circ\text{C)} = 10.000\,001\,4 \text{ k}\Omega$$

This resistance value may be used as given, if the change in resistance for the temperature range to be encountered is acceptably small. For example, if the temperature variations from a nominal 23°C, found in a usual calibration laboratory environment, are less than ±2°C, this would result in a worst case resistance change of less than -0.3 ppm (0.3 ppm = +0.14 ppm at 23°C less -0.16 ppm at 21°C; see chart (2)). If this is an acceptable change, then no temperature correction is required.

**Note:** In the following discussion and in Figure 3-1,  
 t = temperature as a variable  
 T = measured or calculated temperature

If temperature-correction of the standard is needed, then the temperature T of the standard must be determined. This may be done by using a thermometer placed in the well of the unit. This temperature T may be used in:

- The resistance/temperature curve (3)
- The temperature correction chart (2)
- The formula (4), where α and β are given, and T is the thermometer temperature

Using all three methods in the sample shown in Figure 3-1, a temperature t of 22°C would produce the result of:

$$R_s = 10.000\,000\,1$$

A more precise way of measuring the temperature of the standard is to measure T using the value of the integral RTD temperature sensor resistor. Use the formula (5) to obtain T where R<sub>T</sub> is the measured resistance of the RTD at the temperature to be determined. This temperature may be used as above to correct the resistance of the standard.

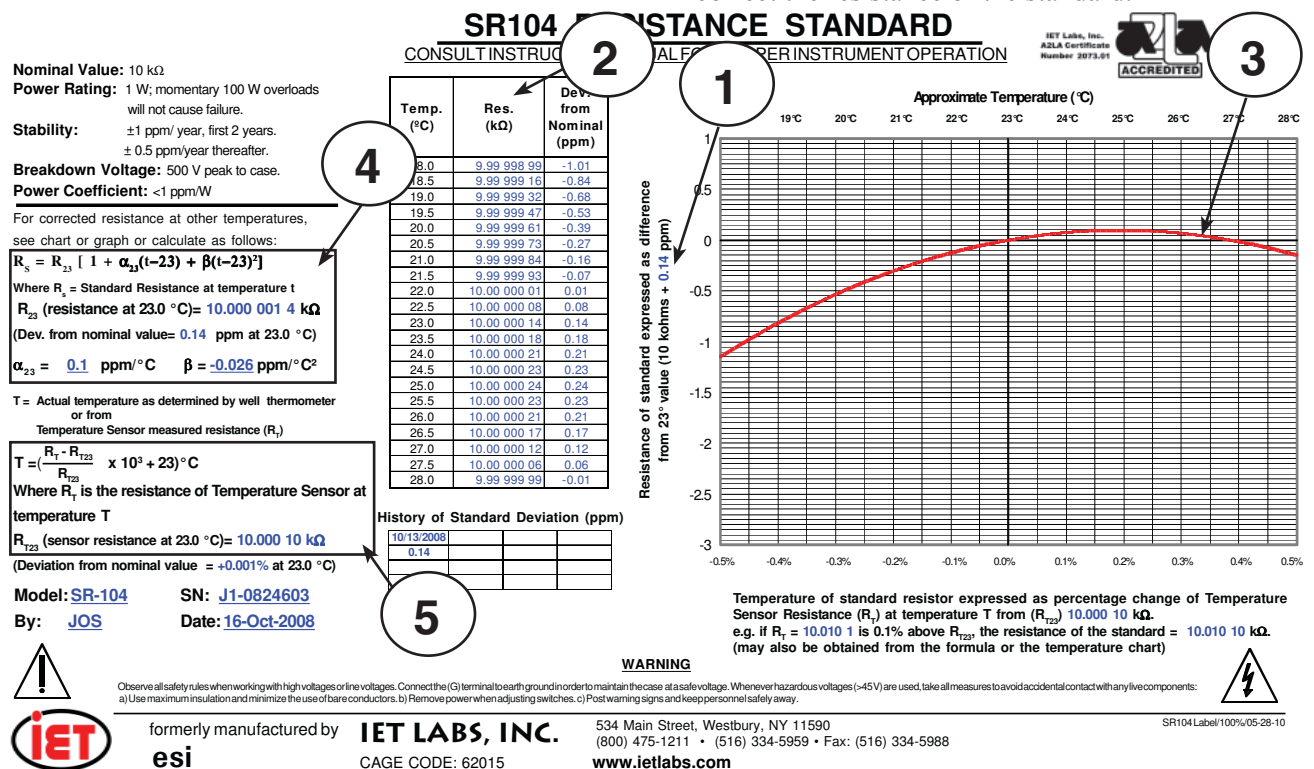

Figure 3-1: Sample temperature correction chart

### 3.3 Schematic Layouts

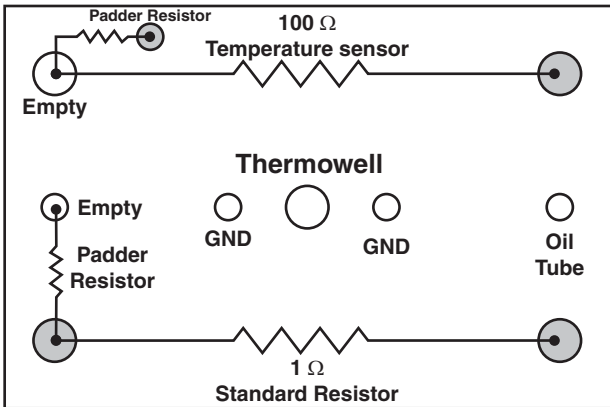

Figure 3-2: SR-100 schematic diagram for test connections, viewed from the top of oil-filled can

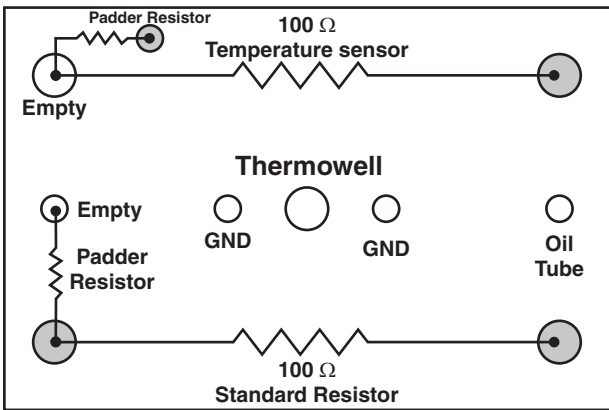

Figure 3-3: SR-102 schematic diagram for test connections, viewed from the top of oil-filled can

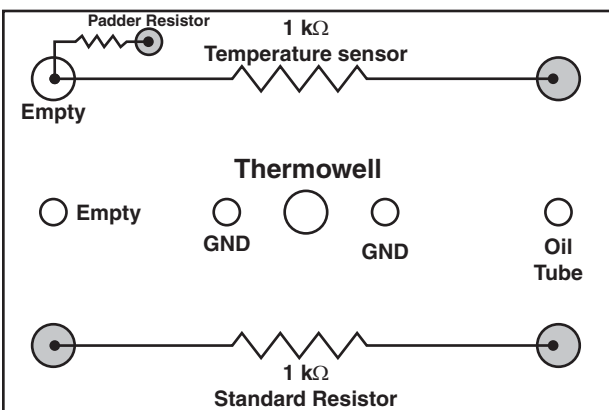

Figure 3-4: SR-103 schematic diagram for test connections, viewed from the top of oil-filled can

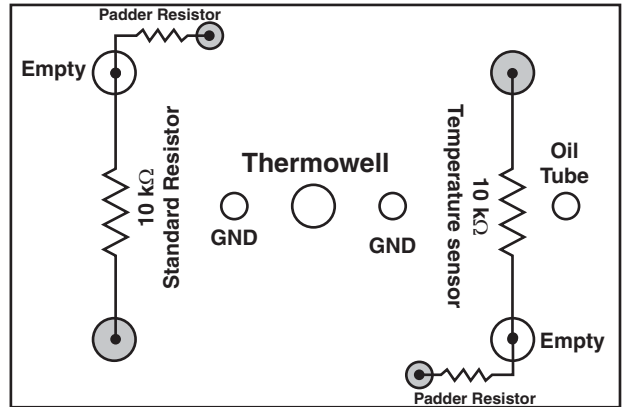

Figure 3-5: SR-104 schematic diagram for test connections, viewed from the top of oil-filled can

### 3.4 Calibrating secondary Resistance Standards

Transportable Resistance Standards are primary standards that establish the resistance levels in the laboratory. Working or secondary standards can be calibrated with these primary standards. Other necessary equipment would be a precision bridge and transfer standards.

In order to eliminate errors from leads, contact resistance, and leakage resistance, IET recommends using a bridge such as the model 242D Resistance Measuring System. This system uses five-terminal measurements -- combination of four-terminal and three-terminal guarded -- that help eliminate these errors.

Resistance transfer standards consists of at least 10 equal resistors (R) that can be connected in series, parallel, or series-parallel. This results in resistance values that are 10R, R/10, or R. The accuracy of these ratios is within 1 ppm.

Once a resistance level is established on a bridge, transfer standards can calibrate the remaining decades by transferring decades to decades above or below the established level. Using a set of transfer standards, you can establish and verify resistance decades on bridges from 0.1 Ω through 100 MΩ.

For values below 1 M $\Omega$ , models SR1030 or SR1010 Transfer Standards are recommended because of the four-terminal connection that preserves accuracy between series and parallel connections.

For values above 1 M $\Omega$ , model SR1050 Transfer Standards are recommended .

For details about the application of 242D, SR1010, SR1030, SR1050, or SR1060, consult their respective manuals.

### 3.5 Bridge connections

A standard resistor can be used either as an interchange standard or as a comparison standard, depending on the type of bridge. An interchange standard is most commonly used because it is either the most accurate, or its accuracy is the easiest to verify. Many bridges have internal standards and can use the standard resistor only for interchange comparisons.

Other bridges have external standard connections and can be used to compare the ratio of two resistors. The interchange technique in this case uses a tare resistor for the external standard of the comparison bridge. The tare resistor is adjusted so that the bridge reading is correct for the value of the standard resistor and other resistors can be compared to the standard.

#### 3.5.1 Wheatstone Bridge

Wheatstone bridges do not generally have provision for external standards. The connections shown in Figure 3-5 are for typical Wheatstone bridges to be used for interchange comparisons.

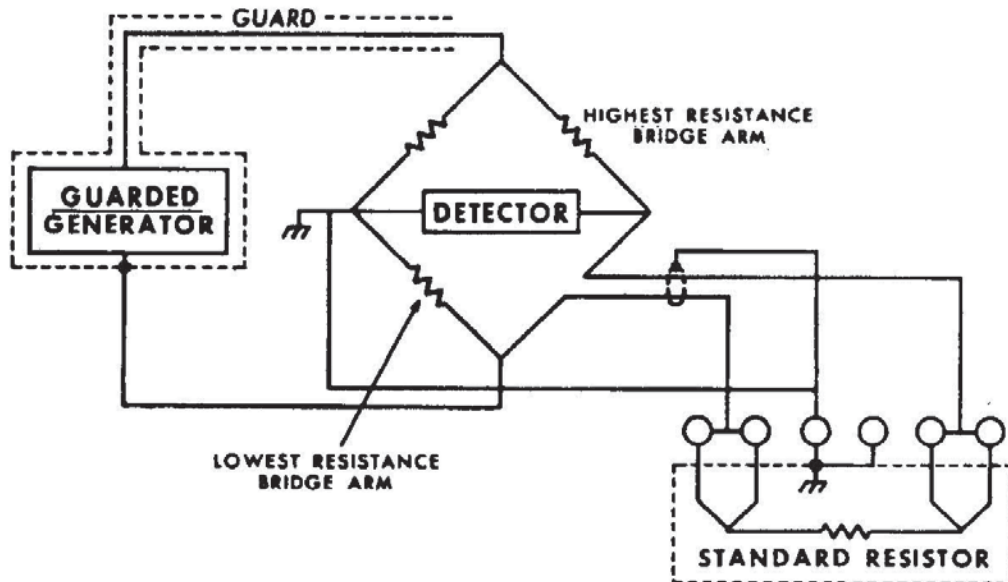

Figure 3-6: Wheatstone bridge connections

### 3.5.2 Kelvin Bridges

Many Kelvin bridges can be used for comparison measurements. The connections in the Figure 3-6 show the bridge connected for interchange measurements. The resistor, where optional, is connected to the indicated terminals.

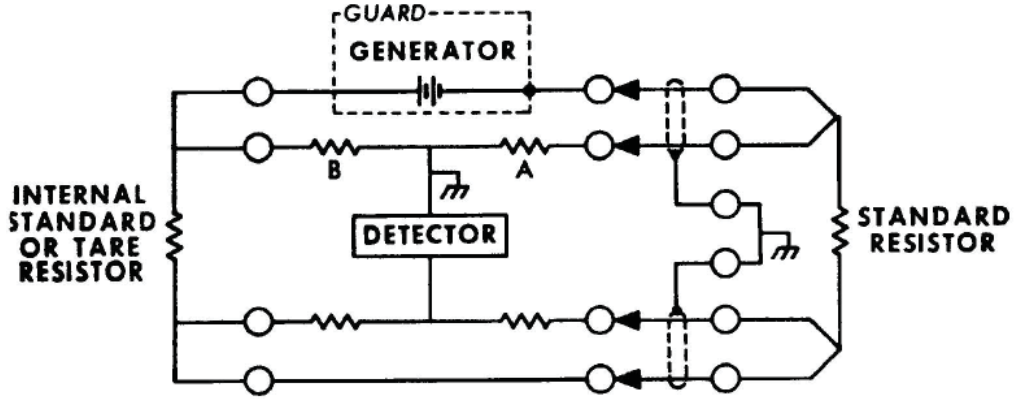

Figure 3-7: Kelvin bridge connections

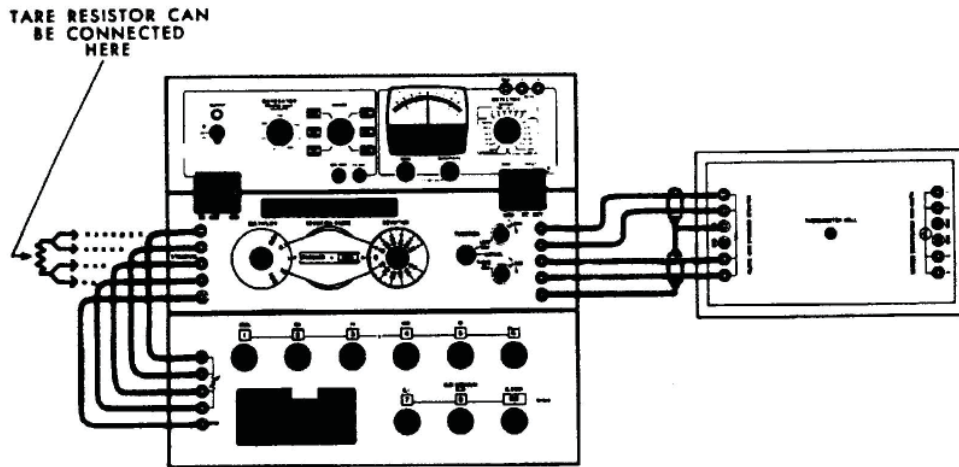

Figure 3-8: Model 242D Resistance-Measuring System Connection



