

OPERATING INSTRUCTIONS

TYPE 1806-A

ELECTRONIC VOLTMETER

Form 1806-0100-C

March, 1967

Copyright 1963 General Radio Company
West Concord, Massachusetts, USA

GENERAL RADIO COMPANY
WEST CONCORD, MASSACHUSETTS, USA

SPECIFICATIONS

DC VOLTMETER

Voltage Range: Four ranges, 1.5, 15, 150, and 1500 V, full scale, positive or negative. Minimum reading is 0.005 V.

Input Resistance: 100 M Ω , $\pm 5\%$; also "open grid" on all but the 1500-V range. Grid current is less than 10^{-10} A.

Accuracy: $\pm 2\%$ of indicated value from one-tenth of full scale to full scale; $\pm 0.2\%$ of full scale from one-tenth of full scale to zero. Scale is logarithmic from one-tenth of full scale to full scale, permitting constant-percentage readability over that range.

AC VOLTMETER

Voltage Range: Four ranges, 1.5, 15, 150, and 1500 V, full scale. Minimum reading on most sensitive range is 0.1 V.

Input Impedance: Probe, approximately 25 M Ω in parallel with 2 pF; with TYPE 1806-P2 Range Multiplier, 2500 M Ω in parallel with 2 pF; at binding post on panel, 25 M Ω in parallel with 30 pF.

Accuracy: At 400 c/s, $\pm 2\%$ of indicated value from 1.5 V to 1500 V; $\pm 3\%$ of indicated value from 0.1 V to 1.5 V.

Waveform Error: On the higher ac-voltage ranges, the instrument operates as a peak voltmeter, calibrated to read rms values of a sine wave or 0.707 of the peak value of a complex wave. On distorted waveforms the percentage deviation of the reading from the rms value may be as large as the percentage of harmonics present. On the lowest range the instrument approaches rms operation.

Frequency Characteristic: Low-frequency roll-off is less than 3% at 20 c/s. Above 150 V with internal voltage divider, there is an additional error of not more than $\pm 2\%$ for frequencies below 500 kc/s.

Probe resonant frequency is above 3000 Mc/s. Above several hundred megacycles per second, probe should be used in a 50- Ω coaxial system with the TYPE 1806-P1 Tee Connector.* Low-frequency roll-off is then less than 3% at 1 kc/s. At high frequencies and low voltages, the error is a function of input voltage level, owing to transit-time effects, as shown in the accompanying plot. Total error is less than ± 3 dB below 1500 Mc/s.

Low-frequency roll-off of the combined voltmeter and multiplier is less than 3% at 10 kc/s. At high frequencies, the multiplier does not affect the over-all voltmeter response.

OHMMETER

Range: 0.2 Ω to 1000 M Ω in four ranges with center scale values of 10 Ω , 1 k Ω , 100 k Ω , and 10 M Ω .

Test Voltage: The dc test voltage is positive and never exceeds 1.5 V. The maximum current (which is delivered to a short circuit on the lowest resistance range) is approximately 43 mA. The maximum available power from the ohmmeter circuit is 16 mW.

Accuracy: $\pm 5\%$ of indicated value from 1 to 10 on scale, approaching $\pm 10\%$ of indicated value at 100 on scale.

GENERAL

Power Required: 105 to 125 or 210 to 250 V, 50 to 400 c/s, 20 W approximately. The case is grounded by the third wire in the power cord. The voltmeter circuit can be disconnected from the case and operated as much as 300 V dc off ground. The low input terminal remains by-passed to the case.

Probe Storage: A socket and reel store both probe and cable.

Accessories Supplied: Spare fuses, CAP-22 Power Cord (on rack model only), an assortment of probe tips for various types of connections.

MECHANICAL DATA

Model	Width		Height		Depth		Net Weight		Shipping Weight	
	in	mm	in	mm	in	mm	lb	kg	lb	kg
Portable	7½	190	8½	220	11½	295	10	4.6	13	6

Patent No. D 187,740.

* (refer to page 4).

For a more detailed description, see *General Radio Experimenter*, July 1963.

Specifications for accessories are on following page.

TYPE 1806-P1 TEE CONNECTOR

General: The Type 1806-P1 Tee Connector screws onto the probe in place of the regular probe tip. It permits connection of the probe across a 50-ohm coaxial line and must be used if the full 1500-Mc frequency range of the voltmeter is to be realized.

Frequency Characteristic: Low-frequency roll-off of the voltmeter and tee connector combination is less than 3% at 1 kc. At high frequencies the voltmeter response is a function of the input voltage level because of transit-time effects, as shown in the accompanying plot. Total error is less than ± 3 db below 1500 Mc.

VSWR: The VSWR of the tee connector and probe is less than 1.1 below 1000 Mc.

Connectors: General Radio Type 874 locking connectors are used.

Dimensions: 4 by 1 by 1-1/8 inches (105 by 26 by 29 mm).

Net Weight: 3½ ounces (0.2 kg).

Shipping Weight: 1 pound (0.5 kg).

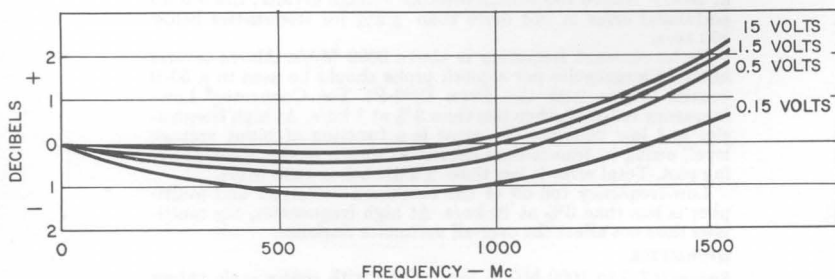

TYPE 1806-P2 10:1 RANGE MULTIPLIER

General: The Type 1806-P2, 10:1 Range Multiplier screws onto the probe in place of the regular probe tip. It consists of a capacitive voltage divider that provides a ten-to-one reduction between the voltage applied to the multiplier and the voltage applied to the probe. It extends the range of voltage measurements that can be made directly with the probe to 1500 volts.

Multiplication Ratio: 10:1 $\pm 5\%$. An adjustment is provided to permit the user to match the multiplier to his Type 1806-A Electronic Voltmeter to within $\pm 2\%$.

Frequency Characteristic: Low-frequency roll-off of the voltmeter and multiplier combination is less than 3% at 10 kc. At high frequencies, the multiplier does not affect the over-all voltmeter response.

Input Impedance: Equivalent input resistance of the probe-multiplier combination is approximately 100 times that of the probe alone. The equivalent parallel capacitance is approximately 2.5 pf.

Dimensions: Diameter, 5/8 inch (16 mm);

Length, 1-1/4 inches (32 mm).

Net Weight: 1/2 ounce (15 grams).

Shipping Weight: 3 ounces (85 grams).

TABLE OF CONTENTS

Section 1. INTRODUCTION	1
1.1 Purpose	1
1.2 Description	1
1.3 Controls	2
1.4 Connectors	3
1.5 Accessories Supplied	3
1.6 Accessories Available	4
Section 2. INSTALLATION	5
2.1 Opening and Tilting the Cabinet	5
2.2 Power Supply	5
2.3 Adjustment of Mechanical Zero	6
2.4 Adjustment of Electrical Zeros	6
2.5 Ohmmeter Full-Scale Check	6
Section 3. OPERATING PROCEDURE	7
3.1 DC Voltage Measurements	7
3.2 AC Voltage Measurements	8
3.3 Resistance Measurements	11
3.4 DC Current Measurements	12
Section 4. PRINCIPLES OF OPERATION	13
4.1 DC Voltage Measurements	13
4.2 AC Voltage Measurements	15
4.3 Resistance Measurements	16
Section 5. SERVICE AND MAINTENANCE	17
5.1 General	17
5.2 Disassembling Procedure	18
5.3 Identification of Trouble	18
5.4 Recalibration	23

Figure 1-1. The Type 1806-A Electronic Voltmeter.

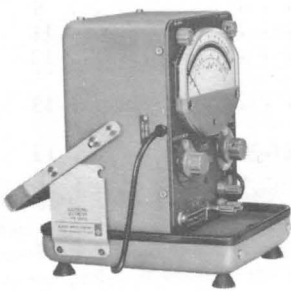

SECTION 1**INTRODUCTION****1.1 PURPOSE.**

The Type 1806-A Electronic Voltmeter (Figure 1-1) is a high-input-impedance, wide-range voltmeter. It is used for the measurement of ac and both positive and negative dc voltages, up to 1500 volts. With the addition of the Type 1806-P1 Tee Connector accessory, it can measure accurately ac voltage on a 50-ohm coaxial line at frequencies up to 1500 Mc. It can also be used as an ohmmeter, for the measurement of dc resistance from 0.2 ohm to 1000 megohms.

1.2 DESCRIPTION.

The voltmeter is basically a very stable dc voltage amplifier having a vacuum-tube input stage, which provides high input impedance and low grid current. The output from the amplifier is fed to the meter, which is connected in series with one of several resistors; the meter range is determined by the resistor selected.

A probe containing a vacuum diode rectifies the ac signal for ac voltage measurements. The above-mentioned dc voltage amplifier is



TYPE 1806-A ELECTRONIC VOLTMETER

then used to measure the resultant dc signal. Except on the lowest ac range, the voltmeter is essentially a peak-responding instrument for the measurement of ac voltage; however, it is calibrated to read the rms value of an applied sinusoidal voltage.

For resistance measurements, a regulated voltage source, in series with one of four range-determining resistors, is connected to the input terminals so that the unknown resistance can be determined by the measurement of the voltage drop across it.

This voltmeter is available in two models. The Type 1806-A is a portable, bench model in a Flip-Tilt case. This model can be set up with its panel at any angle from horizontal to vertical, for convenient, error-free operation. The Type 1806-AR is the same instrument electronically, but is mounted in a relay-rack cabinet, especially designed to minimize the required rack height.

1.3 CONTROLS.

The following controls are on the panel of the Type 1806-A Electronic Voltmeter:

NAME	TYPE	FUNCTION
MEASUREMENT	5-position rotary switch	Turns instrument on and selects type of measurement, AC, DC+, DC-, Ω .
VOLTS FULL SCALE	4-position rotary switch	Selects range of voltage or resistance.
DC ZERO	Continuous rotary control	Adjusts meter zero on DC and Ω ranges.
AC ZERO	Continuous rotary control	Adjusts meter zero on AC ranges.
DC INPUT RESISTANCE	2-position rotary switch (screw-driver control)	Selects input resistance for DC voltage measurements (except on 1500-volt range).

1.4 CONNECTORS.

Binding posts on the front panel provide connections for resistance and dc voltage measurements; they can also be used for ac voltage measurements when the probe is in its storage socket, except when insulated probe accessories are used. A removable link allows the low input terminal to be connected to or disconnected from the case, which is permanently grounded by the third wire of the power cord.

The probe for ac measurements can be stored in the socket provided on the front panel, or it can be withdrawn for convenient connection to measurement points. The probe and its cable can be extended approximately 3-1/2 feet. The cable is then rewound on its storage reel when it is simply pushed back into the instrument.

The power cord is permanently attached to the left side of the front panel. When the cover is closed over the panel, the power cord can be wrapped around the large rubber feet for storage.

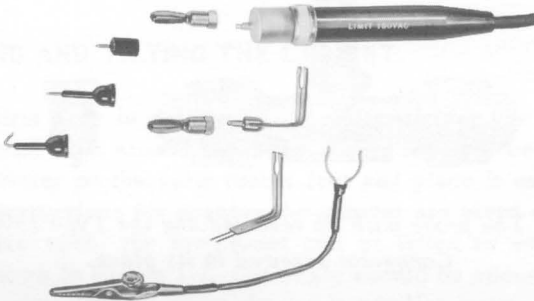

Figure 1-2. The probe and various tip and ground-clip connection accessories.

1.5 ACCESSORIES SUPPLIED.

Several different probe-tip connectors and ground clips are supplied with the voltmeter for ac voltage measurements (Figure 1-2). Storage space for these accessories is provided in the foam-plastic "sandwich" inside the cover of the case.

Spare fuses are also supplied with the instrument.



TYPE 1806-A ELECTRONIC VOLTMETER

1.6 ACCESSORIES AVAILABLE.

For measurements at frequencies greater than several hundred megacycles, the Type 1806-P1 Tee Connector is an essential accessory (Figure 1-3). It allows the probe to be connected across a 50-ohm coaxial line with minimum disturbance to the system. (Refer to specifications.)

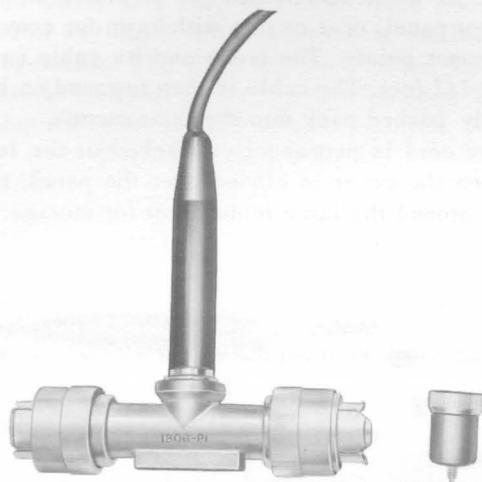

Figure 1-3. The probe with tip removed and the Type 1806-P1 Tee Connector screwed in its place.

The probe can be used directly for voltage measurements only up to 150 volts. The Type 1806-P2 10:1 Range Multiplier can be substituted for the regular tip, to permit measurements with the probe of voltage up to 1500 volts (refer to specifications).

SECTION 2**INSTALLATION****2.1 OPENING AND TILTING THE CABINET.**

The first step in setting up the voltmeter for use is to unwrap the power cord from around the large rubber feet on the cover. Then set the voltmeter on the same rubber feet and place it on a level surface. The instructions for opening the cabinet are given on its handle support. Once open, the instrument can be tilted to any convenient angle, as shown in Figure 1-1. The angle should be chosen to give the view of the meter which offers the least parallax error. When the instrument is open, the cover forms a convenient storage place for the probe accessories in the foam plastic "sandwich".

The instrument can be locked fully open by the same slide pins that are used to lock the instrument closed. Thus, the instrument can be carried in the open position, with the cover firmly in place.

2.2 POWER SUPPLY.

Connect the Type 1806-A to a source of power as indicated by the legend at the point of attachment of the power cord. While instruments are normally supplied for 115-volt operation, the power transformer can be reconnected for 230-volt service (see schematic diagram,



Figure 5-8). When changing connections, be sure to replace line fuses with those of the correct current rating for the new input voltage (refer to Parts List). Appropriate measures should be taken so that the legend indicates the new input voltage. On instruments changed from 230 to 115 volts, this simply means removal of the 230-v label plate; a 115-v legend is marked beneath. For instruments changed from 115 to 230 volts, a plate (Type 5590-1664) may be ordered from General Radio.

The third wire of the power cord is permanently connected to the case. Note that the electrical shock-hazard protection afforded by the third wire is not in effect if, for any reason, the third wire is not connected to external ground.

2.3 ADJUSTMENT OF MECHANICAL ZERO.

Before turning on the instrument, adjust the screw on the face of the meter, if necessary, to set the pointer exactly on zero.

2.4 ADJUSTMENT OF ELECTRICAL ZEROS.

The electrical zero for the measurement of DC+, DC-, and Ω is set by the DC ZERO control. To make this adjustment, turn the MEASUREMENT knob to DC+ and allow five or ten minutes for the instrument to warm up. Set the VOLTS FULL SCALE knob to 1.5. Short-circuit the input binding posts (red to gray) and adjust the DC ZERO control so that the meter indicates exactly zero. The same procedure can be followed with the MEASUREMENT knob set at DC- or Ω .

With the binding posts still short-circuited and with the probe in its storage socket, turn the MEASUREMENT knob to AC. Adjust the AC ZERO control so that the meter again indicates exactly zero.

2.5 OHMMETER FULL-SCALE CHECK.

Remove the short-circuit from the input binding posts and turn the MEASUREMENT knob to Ω . The meter should indicate exactly full scale. This ohmmeter test voltage is derived from the regulated power supply for the vacuum-tube heaters, and full-scale reading by the meter indicates that the voltage is adjusted properly.

SECTION 3

OPERATING PROCEDURE

3.1 DC VOLTAGE MEASUREMENTS.

3.1.1 CONNECTIONS. Make all dc voltage measurements with the voltage source connected to the input binding posts on the front panel. The red binding post is the high terminal; the gray binding post is the low terminal. The link is used to connect the low terminal to the metallic binding post, which is the cabinet and the third-wire ground connection. With the MEASUREMENT knob in the DC+ position, an upscale deflection of the meter indicates that the voltage at the red binding post is positive with respect to that at the gray; when the switch is in the DC- position, an upscale deflection indicates that the red post is negative with respect to the gray. The gray binding post is the low terminal in the sense that it has much greater capacitance to the case ground than has the red binding post.

WARNING

Voltages up to 1500 volts can be measured with this instrument, and such voltages are extremely dangerous. Be sure to exercise considerable caution when making connections or when operating the voltmeter for high-voltage measurements.

3.1.2 POLARITY AND RANGE. Turn the MEASUREMENT knob to either the DC+ or the DC- position, depending upon the anticipated polarity of the voltage to be measured. Turn the VOLTS FULL SCALE knob to the range that is somewhat greater than the expected voltage.



3.1.3 INPUT RESISTANCE. The DC INPUT RESISTANCE switch is a screwdriver control near the center of the panel. On the three lower dc voltage ranges, the switch connects or disconnects a 100-megohm resistance across the input terminals. The resistance is always connected on the 1500-volt DC+ and DC- ranges. When the DC INPUT RESISTANCE switch is set to the 100M position, the indicator of the meter will return to near zero between measurements, and the input resistance will not change when the VOLTS FULL SCALE switch is changed to and from the highest voltage range. When the DC INPUT RESISTANCE switch is set on the OPEN GRID position, the 100-megohm resistance is disconnected on the three lowest voltage ranges and the voltmeter operates with "open grid". This makes possible the measurement of dc voltages from sources whose resistances are as large as 100 to 1000 megohms. The grid current is less than 10^{-10} ampere; to compensate for the voltage impressed on the source by this current, connect an external resistor of the same value as the output impedance of the voltage source across the input terminals of the voltmeter; then set the meter to zero.

3.1.4 UNGROUNDED OPERATION. To use the voltmeter with neither input terminal grounded, remove the link between the gray and the metal binding posts. The low terminal (gray) can then be connected to a circuit point that is as much as 300 volts dc from ground. A .01- μ f capacitor bypasses the low input terminal to the grounded cabinet at all times. Do not connect the low terminal to a voltage that has an ac component with respect to ground. Removal of the link is intended only for connection of the low terminal to a point whose voltage differs from ground by dc, not by ac. When the link is removed for the purpose of making dc off-ground measurements, be sure the probe is in its storage socket, to avoid damage to equipment or injury to personnel by accidental contact with the ground shell of the probe, which is permanently connected to the low (gray) binding post.

3.2 AC VOLTAGE MEASUREMENTS.

3.2.1 CONNECTIONS. The voltmeter provides two methods for measuring ac voltages. The probe can be removed from its socket and connected directly to the circuit point of interest; or the probe can be placed in its storage socket and the ac voltage can then be applied to the input binding posts. The maximum voltage that should be applied directly to the probe is 150 volts, rms sine-wave, or 212 volts peak. For

the measurement of ac voltages over 150 volts, rms, place the probe in its storage socket and connect the input to the input binding posts.

WARNING

Do not apply more than 150 volts, rms, or 212 volts, peak, ac signal to the probe. Do not apply more than 600 volts dc to the probe.

3.2.2 PROBE ACCESSORIES. Several different ground-connection devices and probe-tip connectors are supplied with the instrument. Storage space for these is provided in the foam-plastic sandwich in the cover of the instrument. Select the most convenient of these devices for the high and ground connections to the probe. Some of the possible combinations are shown in use in Figure 3-1. Connect the shell of the probe to the electrical ground and the tip to the circuit point at which the voltage is to be measured.

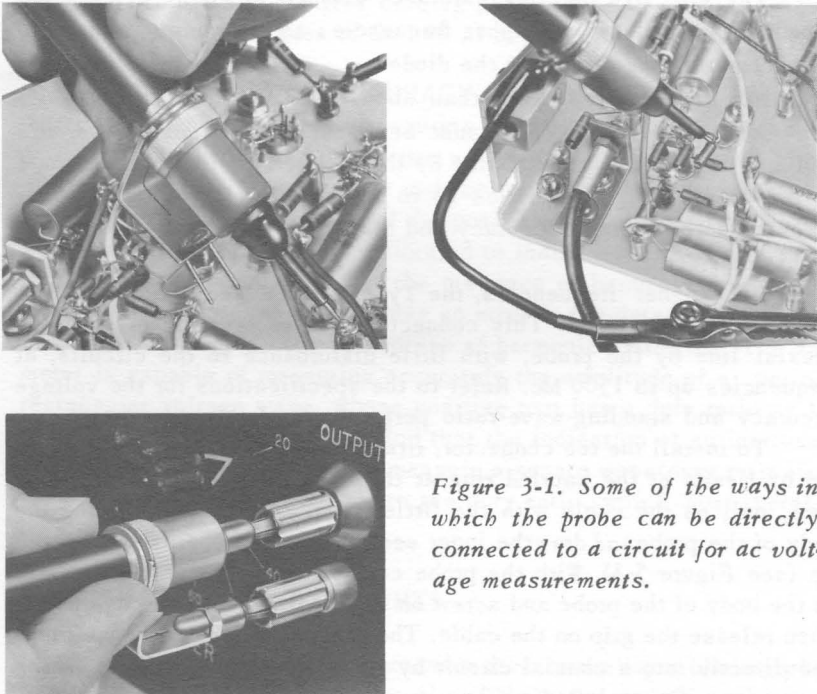
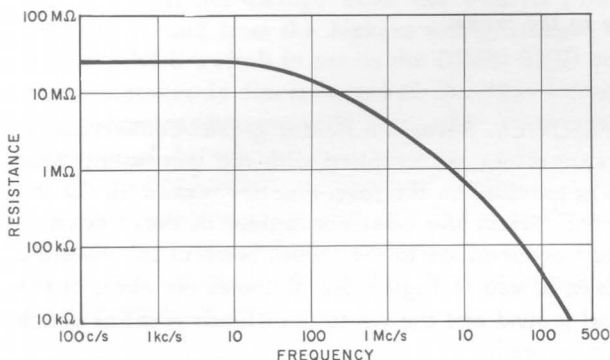

Figure 3-1. Some of the ways in which the probe can be directly connected to a circuit for ac voltage measurements.



3.2.3 FREQUENCY RESPONSE. Measurements at frequencies exceeding 500 kc should be made by direct connection to the probe. With the probe connected directly to the point of interest, voltages at frequencies of the order of several hundred megacycles can be measured, but appreciable errors may appear, depending on the method of connection. For best results, keep the tip and ground connections as short as possible.



*Figure 3-2.
Effective parallel
input resistance
of probe.*

The effective parallel-resistance component of the probe input impedance is reduced at higher frequencies; as shown in Figure 3-2, due to transit-time effects in the diode.

For frequencies higher than about 200 Mc, the Type 1806-P1 Tee Connector (Figure 1-3) must be used. This connector permits bridging of a 50-ohm coaxial line by the probe, with little disturbance to the circuits, at frequencies up to 1500 Mc. Refer to the specifications for the voltage accuracy and standing-wave ratio performance of this connector.

For higher frequencies, the Type 1806-P1 Tee Connector (Figure 1-3) must be used. This connector permits bridging of a 50-ohm coaxial line by the probe, with little disturbance to the circuits, at frequencies up to 1500 Mc. Refer to the specifications for the voltage accuracy and standing-wave-ratio performance of this connector.

To install the tee connector, first unscrew the gray plastic probe tip by means of the knurled ring at the base of the tip. At the same time, pull on the cable with the little finger of the hand holding the body of the probe and draw the inner section of the probe away from the tip (see Figure 5-3). With the probe cap removed, keep the same grip on the body of the probe and screw on the tee connector until it is tight. Then release the grip on the cable. The tee connector can then be plugged directly into a coaxial circuit by means of the Type 874 Locking Connectors. General Radio Company adaptors for other types of con-

nectors can be locked onto the Type 1806-P1 Tee Connector for convenient use in coaxial systems using other types of connectors.

WARNING

Because of the losses due to transit time in the diode, the voltage applied to the probe must be reduced at high frequencies. Above 200 megacycles this reduction must be in inverse proportion to the frequency, as exemplified in the table below.

FREQUENCY	200	500	1000	1500 Mc
MAXIMUM VOLTAGE	150	60	30	20 volts

Keep the link connected between the metal and the gray binding posts for all ac measurements. Even when the link is disconnected, there remains an internal .01 μ f capacitor connected between the gray and the metal binding posts, which tends to bypass directly to the power-line ground any ac voltage that may be connected to the gray binding post. Make sure the third wire is properly grounded; if it is not, the cabinet and the gray binding post will be at the same ac potential to ground, because of the .01 μ f capacitor.

3.2.4 DEPENDENCE OF ACCURACY UPON WAVEFORM. This voltmeter is essentially a peak-measuring instrument for ac voltages, but it is calibrated in terms of the rms value of a sine-wave input signal. The operation of the voltmeter may be more accurately described as measuring the height in volts of the positive peak of the input voltage above its average, and it is calibrated to indicate 0.707 of this value. It should be kept in mind that the presence of harmonic distortion in a periodic input voltage may cause an error in the determination of the rms value as large as the percentage of harmonic distortion. The voltmeter is capable of measuring accurately the amplitude of a periodic rectangular voltage wave, whose positive part has a duty ratio as low as .001. It should be kept in mind that the indication of an instrument of this type, when it is used to measure a square wave (duty ratio about 0.5), is inversely proportional to the duty ratio, which must therefore be known accurately.

3.3 RESISTANCE MEASUREMENTS.

To measure resistances, connect them to the input binding posts. Set the MEASUREMENT knob to Ω and the range switch to the range



TYPE 1806-A ELECTRONIC VOLTMETER

that gives the nearest to mid-scale meter indication. Each succeeding range changes the ohms range by a factor of 100. Make the reading on the range that gives an indication between 1 and 100 on the ohms scale.

If test leads are used for low-resistance measurements, the resistance of the leads must be measured separately and subtracted from the total measured resistance. For the most accurate zero adjustment, short-circuit the input binding posts, turn the VOLTS FULL SCALE switch to the X100 (or higher) resistance range, and adjust the zero by means of the DC ZERO control. Accurate adjustment of the DC ZERO on the DC, 1.5 v range is exactly equivalent to making this ohmmeter zero adjustment.

The open-circuit test voltage for resistance measurements is 1.5 volts. The red binding post is positive. The maximum available power from the ohmmeter is 16 mw and the maximum available current is 43 ma.

WARNING

Do not allow a source of high voltage to come in contact with the input binding post when the MEASUREMENT knob is in the Ω position. This may damage the ohmmeter resistors or the low-voltage regulated supply.

3.4 DC CURRENT MEASUREMENTS.

The voltmeter can easily be converted for the measurement of small direct currents. To do so, turn the MEASUREMENT knob to either DC+ or DC-, the VOLTS FULL SCALE knob to 1.5, and the DC INPUT RESISTANCE control to OPEN GRID. Then connect the appropriate shunt resistor across the input binding posts. Table 3-1 gives the full-scale current ranges for various values of the shunt resistor.

TABLE 3-1
SHUNT RESISTOR VALUES FOR DC CURRENT MEASUREMENT.

RESISTOR	FULL-SCALE CURRENT
100 megohms	15 nanoamperes
10 megohms	150 nanoamperes
1 megohm	1.5 microamperes
100 kilohms	15 microamperes
10 kilohms	150 microamperes

SECTION 4

PRINCIPLES OF OPERATION

4.1 DC VOLTAGE MEASUREMENTS.

When used for dc voltage measurements, the circuit of the Type 1806-A functions as a pair of cathode followers, driving the meter from cathode to cathode. Each cathode follower is made up of two vacuum tubes and one transistor, so connected as to operate much nearer to the ideal than is possible with one tube alone. Figure 4-1 is a simplified schematic diagram of this amplifier circuit.

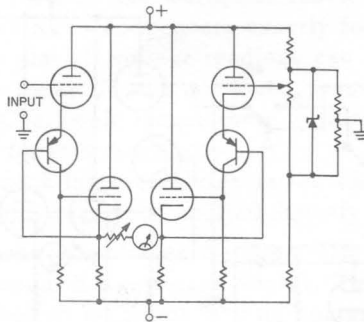

Figure 4-1. Simplified diagram of dc amplifier.



TYPE 1806-A ELECTRONIC VOLTMETER

The first tube is connected as a simple cathode follower and is operated at reduced plate current and reduced heater voltage, to minimize grid current. The transistor and the second tube comprise a circuit which possesses a number of desirable characteristics. First, the input impedance (at the emitter) is extremely high, being approximately equal to the collector resistor in value. This means that the gain of the first tube is very closely equal to $\mu/(\mu + 1)$, a term which is substantially invariant during the lifetime of the tube. The gain of the transistor-tube circuit, highly stabilized by feedback, differs from unity by only a few parts per million, so the voltage gain of the entire circuit is quite independent of the gradual decrease in transconductance that occurs as the tubes age.

Secondly, the output impedance of this circuit is less than one ohm, due to the high gain enclosed in its feedback loop; consequently, the variation in output impedance with tube aging is completely negligible.

The B-supply voltages in the instrument are large enough to permit input voltages up to 150 volts to be applied directly to the grid of the input tube. On the 1500-volt range, a 10-to-1 resistive voltage divider is connected between the binding posts and the input grid. This divider has a resistance of 100 megohms. On the three lower ranges, the entire divider is either connected as an input grid leak or is disconnected, by means of the DC INPUT RESISTANCE switch. When the loading of the 100-megohm resistor upon a high-resistance source is undesirable, the switch can be turned to the OPEN GRID position. The 100-megohm resistor is always connected on the 1500-volt range.

A simplified schematic diagram of the entire instrument is shown in figure 4-2.

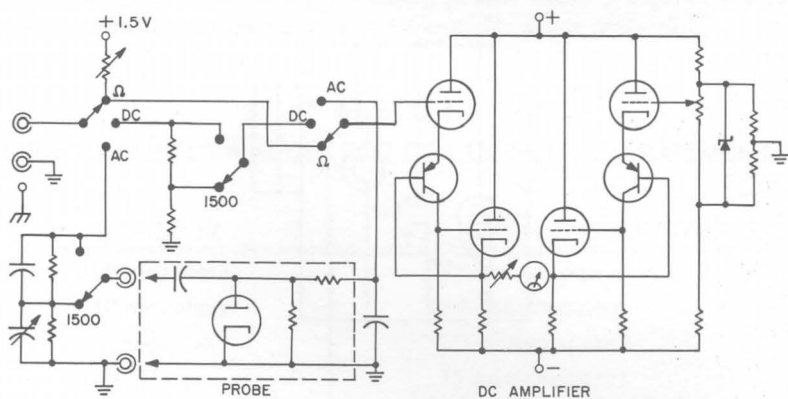

Figure 4-2. Simplified diagram of complete voltmeter.

4.2 AC VOLTAGE MEASUREMENTS.

For ac voltage measurements, a rectifier diode is connected to the ac source, and the output of the rectifier circuit is measured with the dc amplifier. The diode is particularly suitable for high-frequency operation and is mounted in a small probe. The probe can either be connected to the circuit at the point where the voltage is to be measured, or it can be placed in its storage socket, with the ac voltage then applied to the input binding posts. The probe rectifier circuit is shown in Figure 4-3. A small dc bias is applied to the shunt resistor, which standardizes the rectification efficiency of the diodes at low levels, to improve the accuracy of low-level ac measurements.

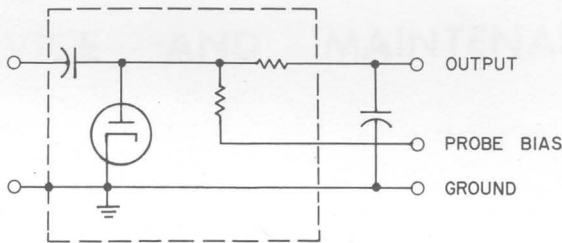

Figure 4-3. Schematic diagram of probe circuit.

A network of diodes and resistors is connected in parallel with the multiplier resistor that is in series with the meter, on the AC 15- and 150-volt ranges. The 6.3-volt regulated supply provides voltages which bias the diodes on when there is no input signal. The action of this network is to make the multiplier resistance effectively non-linear in such a way as to compensate exactly for the non-linearity of the probe diode, so that all voltage readings can be made on the same linear scale of the meter. It was not found possible to design such a network for the AC 1.5-volt range; there is, therefore, an additional scale on the meter for this range only.

Due to the peak-inverse-voltage rating of the diode, voltages greater than 150 volts cannot be applied directly to the probe circuit. For the measurement of voltages between 150 and 1500 volts, the probe must be inserted in its storage socket. The voltage to be measured is then applied to the input binding posts. A capacitance-compensated, resistance-type, 10-to-1 voltage divider inside the cabinet is switched into the circuit on the 1500-volt ac range. Lower voltages



can also be measured with the probe in its storage socket. The upper frequency limit for this type of operation is approximately 0.5 megacycle.

4.3 RESISTANCE MEASUREMENTS.

A voltage divider connected to the regulated 6.3-volt supply provides a source of 1.5 volts, open-circuit having four different internal resistances. This source is connected to the input binding posts and converts the instrument to a voltage-divider-type ohmmeter. The dc voltmeter circuit on the 1.5-volt range measures the voltage drop on the unknown resistance connected across the binding posts. A special meter scale is calibrated in resistance.

SECTION 5

SERVICE AND MAINTENANCE

5.1 GENERAL.

We warrant that each new instrument sold by us is free from defects in material and workmanship, and that, properly used, it will perform in full accordance with applicable specifications for a period of two years after original shipment. Any instrument or component that is found within the two-year period not to meet these standards after examination by our factory, district office, or authorized repair agency personnel, will be repaired, or, at our option, replaced without charge, except for tubes or batteries that have given normal service.

The two-year warranty stated above attests the quality of materials and workmanship in our products. When difficulties do occur, our service engineers will assist in any way possible. If the difficulty cannot be eliminated by use of the following service instructions, please write or phone our Service Department (see rear cover), giving full information of the trouble and of steps taken to remedy it. Be sure to mention the type and serial numbers of the instrument.

Before returning an instrument to General Radio for service, please write to our Service Department or nearest district office, requesting a Returned Material Tag. Use of this tag will ensure proper handling and identification. For instruments not covered by the warranty, a purchase order should be forwarded to avoid unnecessary delay.



5.2 DISASSEMBLING PROCEDURE.

5.2.1 REMOVAL OF INSTRUMENT FROM CABINET. To remove the instrument from its cabinet, remove the four screws from the sides of the cabinet near the front panel, and lift the instrument straight out. Ease the power cord and its rubber grommet out of the keyhole slot in the side of the cabinet.

5.2.2 REMOVAL OF FRONT PANEL. For easy access to the circuit side of the etched board, remove the front panel from the instrument. To do this, unsolder the leads from both the red and gray binding posts (visible from below) and remove the MEASUREMENT and VOLTS FULL SCALE knobs. Take out the seven screws on the front panel and the single screw at the front center on the top shelf. Lift off the front panel and "fold" it over, toward the left of the instrument. If the leads are extended to the binding posts, the instrument can be operated for troubleshooting, with the panel removed. Ground each of the two aluminum shelves to the front panel with clip leads; then replace the MEASUREMENT and VOLTS FULL SCALE knobs on their respective switches.

5.2.3 REMOVAL OF TRANSFORMER. For complete access to the component side of the larger etched board, the transformer must be removed and dropped to the rear. (Its leads can remain connected.) To do this, unscrew the two hexagonal spacers that extend forward from the etched board to the front panel and remove the two screws that hold the rear foot of the transformer to the lower shelf. The small spacers on these screws, between the transformer and the bottom shelf, should be saved for replacement. With these major structural components removed, the remaining parts of the instrument must be handled with care, to prevent breakage.

WARNING

Never attempt to operate the instrument with the transformer unmounted.

5.3 IDENTIFICATION OF TROUBLE.

5.3.1 POWER. When troubleshooting, connect the instrument to the line through a metered Variac autotransformer, if possible, to allow a continuous check on the power being drawn from the line. The power

drain of the Type 1806-A is approximately 22 watts at normal line voltage. Any appreciable departure from this value indicates circuit trouble. If the power consumption is low, failure of either power supply or the opening of the heater of one or more vacuum tubes is indicated. If the power consumption is greater than normal, a short circuit is the possible cause.

Check that the instrument is connected to a power source of the correct voltage and frequency ratings. The pilot lamp should light when the instrument is turned on. If it does not, check (with an ohmmeter) that the lamp is not burned out. Next check the fuses, located at the left rear of the top side of the lower shelf (see Figure 5-1). Disconnect the power cord from the power source before attempting to check or replace the fuses.

If none of the above procedures restore the operation of the instrument, it should be returned to General Radio for further servicing.

5.3.2 LOW-VOLTAGE POWER SUPPLY. Failure of the low-voltage power supply will make the voltmeter completely inoperative, since this supply furnishes power to the heaters of all three vacuum tubes. If the pilot lamp lights, but no indication is obtained on the meter, turn the MEASUREMENT knob to Ω , the VOLTS FULL SCALE knob to X1, and check, with another voltmeter, that there is 6.3 volts between test

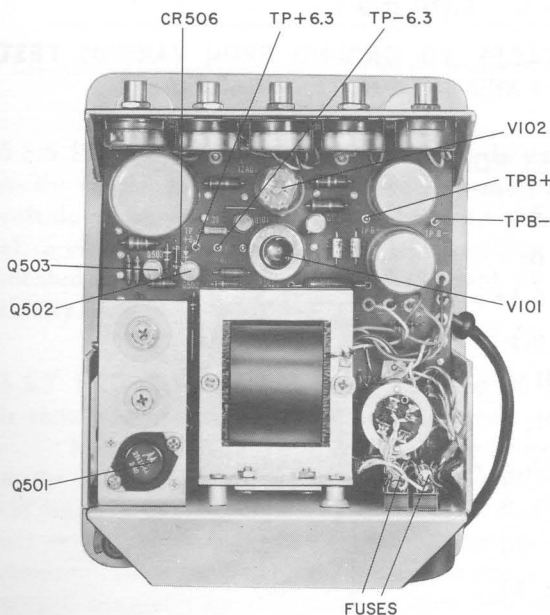

Figure 5-1. Rear view of Voltmeter.



point +6.3 and test point -6.3 on the etched board (see Figures 5-1 and 5-6). If the voltage is not correct, there is probably trouble in the low-voltage, transistorized, regulator circuit. It may be necessary to replace transistor Q502, Q503, Q501, or diode CR506, Figure 5-1.

5.3.3 HIGH-VOLTAGE POWER SUPPLY. The voltage from test point B+ to test point B- (see Figures 5-1 and 5-6) should be approximately 550 volts. This is a simple half-wave rectifier circuit; any troubles that occur in this section should be easily diagnosed. Note that an incorrect output voltage may be due to trouble in the circuit to which it supplies power.

5.3.4 MAIN CIRCUIT TROUBLES. Difficulties with the main dc amplifier circuit, such as failure of a tube, transistor, or other component, can be located by test-voltage measurements. Use a 20,000-ohms-per-volt test meter or a second Type 1806 Electronic Voltmeter. Set the MEASUREMENT knob to DC+ and the VOLTS FULL SCALE knob to 150. Short the red binding post to the gray, and connect the link from the gray to the metal binding post. The correct dc voltages, with respect to the circuit ground (gray binding post), are given in Table 5-1, below. (For locations of these test points, see Figures 5-1 and 5-6.)

TABLE 5-1

CORRECT DC VOLTAGES TO GROUND FROM VARIOUS TEST POINTS (T.P.) AND ANCHOR TERMINALS (A.T.).

TEST POINT	VOLTS
TP B+	+310
TP B-	-240
TP 6.3+	+6.3
TP 6.3-	0
V101, 8	+4.6
V101, 3	+4.6
V102, 3, A.T. 23	+4.0
V102, 8, A.T. 24	+4.0
A.T. 20	+10
A.T. 14	+0.3
A.T. 28	-1.3

5.3.5 MULTIPLIER RESISTORS. If the voltmeter functions correctly on some ranges but not on others, the trouble is undoubtedly in some of the multiplier resistors or their associated switching networks. Determine which ranges are not operating properly and check the corresponding multiplier resistors according to Table 5-2.

TABLE 5-2

MULTIPLIER RESISTORS IN THE CIRCUIT FOR EACH RANGE SETTING.

RANGE SETTINGS	RESISTOR IN CIRCUIT*
DC, 1.5 VOLTS, or Ω	R131
DC, 15 VOLTS	R130
DC, 150 VOLTS and 1500 VOLTS	R128
AC, 1.5 VOLTS	R137
AC, 15 VOLTS	R136 and associated network
AC, 150 VOLTS	R132, R136, and associated network

* See schematic diagram and Parts List for resistance values.

5.3.6 HIGH-VOLTAGE DC DIVIDER. If the instrument operates correctly on the 1.5-, 15-, and 150-volt dc ranges, but not on the 1500-volt dc range, suspect the high-voltage dc divider. The latter consists of a string of resistors totaling 100 megohms, nearly all of which are located at the bottom of the etched board. Check this circuit for continuity.

5.3.7 PROBE. When improper operation of the probe is suspected, it should be opened in the following manner:

First, unscrew the gray plastic tip by means of the knurled ring at the base of the tip; at the same time, pull on the cable with the little finger of the hand holding the body of the probe, and draw the inner section away from the tip (see Figure 5-2). When the tip has been removed, slide the body shell along the cable until the inner components of the probe are accessible (Figure 5-3). If the ceramic diode must be changed, pull the tube out to the side; to replace it, push the new



Figure 5-2. Unscrewing tip from probe. Notice little finger of hand holding cable, to withdraw inner part of probe from tip.

diode in from the side. Be sure to rotate the tube so that the heater buttons pass to either side of the heater contact springs, and so that the cathode contact groove in the side of the diode slides directly into the fingers of the cathode contact spring. Then slide the body shell back over the inner section of the probe.

Use considerable care in all operations on the probe; do not damage any of the inner components, for instance by bending the spring fingers or the anode contact plate. When reassembling, be careful not to snag the tube on the body shell.

5.3.8 HIGH-VOLTAGE AC DIVIDER. If the instrument operates properly on the 1.5-, 15-, and 150-volt ac ranges, but not on the 1500-volt ac range, the difficulty may be in the high-voltage ac divider. This

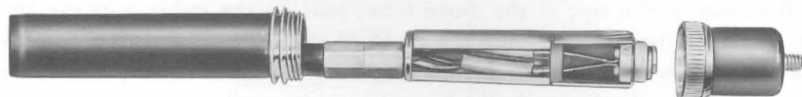

Figure 5-3. Inner section of probe removed from shell.

circuit (Figure 5-7) is located on a small etched board, on the right side of the instrument. Check the components in this circuit.

5.3.9 ZERO ADJUST. If the range of zero adjustment is too large or too small, this may be due to any one of several possible malfunctions. Check that terminal 14 is approximately 1.6 volts more positive than terminal 28. An improper voltage at this point indicates trouble in CR103, CR104, CR105, or CR106. See Figure 5-6 for location of these terminals and components.

5.4 RECALIBRATION.

5.4.1 GENERAL. Complete calibration of the Type 1806-A Electronic Voltmeter requires several low-distortion sources of sinusoidal voltage and a source of dc voltage, all of accurately known amplitude. The accuracy of the recalibration depends upon the accuracy of the test voltages; therefore, a means of measuring the ac and dc test voltages to an accuracy of $\pm 0.5\%$ must be provided. When there is doubt as to the accuracy of the measurement, or if the presence of distortion in the available test voltages is suspected, the voltmeter should be returned to General Radio for recalibration.

The procedure for recalibrating the voltmeter is outlined below, for use where suitable test voltages are available. Be sure to follow the instructions in the order given.

5.4.2 CALIBRATION OF 1.5-, 15-, AND 150-VOLT RANGES. Turn on the instrument and allow it to warm up for 15 minutes. Set the MEASUREMENT knob to DC- and the VOLTS FULL SCALE knob to 1.5. Short-circuit the input and adjust the meter indication to zero. Turn the VOLTS FULL SCALE knob to 150, and connect a source of -150 volts dc, $\pm 0.5\%$, to the input binding posts. Adjust R142, CAL 150 DC, so that the meter indicates exactly full scale. (See Figure 5-4 for location of this control.) Disconnect the voltage, and replace the short circuit at the input. Turn the VOLTS FULL SCALE knob to 1.5 and reset the zero, if necessary. Then connect -1.5 volts dc, $\pm 0.5\%$, to the input binding posts. Adjust R129, CAL 1.5 DC, so that the meter indicates exactly full scale. There is some slight interaction between these two controls, so a recheck of the calibration at -150 volts as de-



TYPE 1806-A ELECTRONIC VOLTMETER

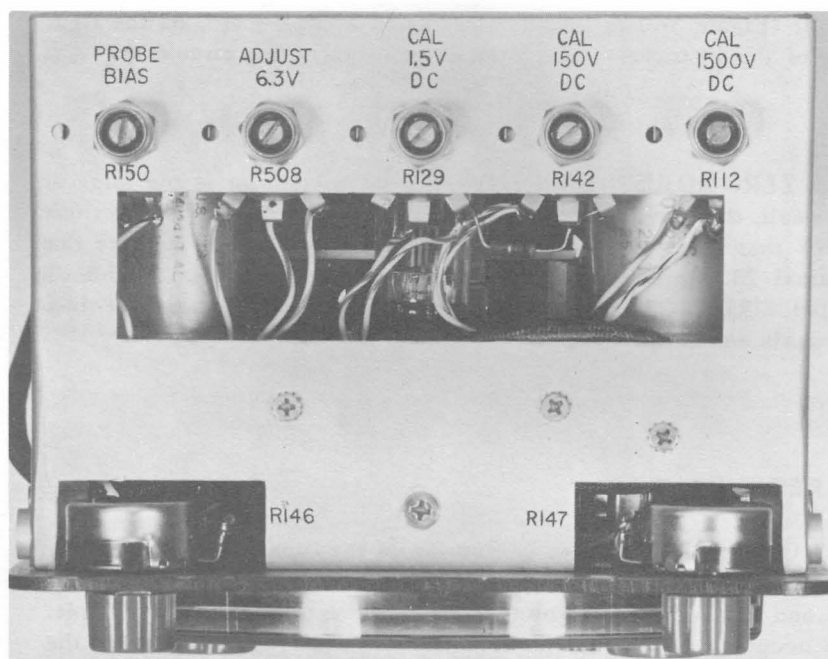

Figure 5-4. Top view of voltmeter.

scribed above should be made. Then check the full scale indication on the 15-volt range. Turn the MEASUREMENT knob to DC+, reverse the polarity of the dc test voltage, and check the full-scale indications on the same three ranges as before. With the use of an accurate voltage divider, such as the General Radio Type 1454-A Decade Voltage Divider, the linearity of the meter deflection can be checked by applying test voltages corresponding to four or five different values, distributed across the scale.

5.4.3 CALIBRATION OF 1500-VOLT DC RANGE. This calibration involves only the setting of the 100-megohm, 10:1, input-voltage divider, in the circuit on this range. Turn the MEASUREMENT knob to DC- and the VOLTS FULL SCALE knob to 150. Apply -150 volts dc to the input binding posts, so that a full-scale deflection is obtained. Then change the VOLTS FULL SCALE switch to 1500 and adjust R112, CAL 1500 DC, to give a meter indication of exactly one-tenth of full scale (1.5 on the outer scale).

5.4.4 OHMMETER ADJUSTMENT. Setting the full-scale indication, i.e., the voltage of the regulated supply, is the only ohmmeter adjustment required. This supply provides the heater power for the diode rec-

tifier in the probe; therefore, it is important that this adjustment be made before the ac voltage ranges are calibrated. Set the MEASUREMENT knob to Ω and the VOLTS FULL SCALE switch to X10K. Short-circuit the input binding posts and set the DC ZERO. Then remove the short circuit and adjust R508, ADJUST 6.3V, so that the meter indicates exactly full scale.

The calibration of each range of the ohmmeter is determined by the value of a precision resistor. Use the following values of resistance standards to check the various ranges: 1, 10, 100, 1k, 10k, 100k, 1M, 10M, and 100M ohms, each $\pm 1\%$. Check three values on each range, at the 1, 10, and 100 points on the meter scale. A significant error on any range indicates that one or more of the resistors are outside the limits and must be replaced. When checking the values of the smaller resistors, be sure to subtract the resistance of any leads that are used.

5.4.5 CALIBRATION OF AC RANGES.

5.4.5.1 General. The calibration of the ac ranges is, for the most part, accomplished by the adjustment of the dc calibration controls, since highly precise multiplier resistors are used on all ranges. However, two additional adjustments are necessary: those of the probe bias and the input voltage divider for the 1500-volt range.

5.4.5.2 Probe Bias Adjustment. The procedure for this adjustment is as follows: After warm-up, set the MEASUREMENT switch to AC and the RANGE switch to 1.5. Short-circuit the input to the probe and set the AC ZERO. Remove the short circuit and apply a low-distortion, 400-cycle, sine-wave signal of 0.2 volt, rms, to the probe. If the voltmeter does not indicate exactly 0.2 on the inner scale, the probe bias must be readjusted. Keep the ac signal connected. If the meter indication is too low, adjust R150, PROBE BIAS, to give a lower indication; if it is too high, adjust R150 for a higher indication. Then remove the signal, short circuit the input, and reset the AC ZERO. Again, apply the precise 0.2-volt signal and check that the meter indication is now exactly 0.2. Repeat this procedure until the desired accuracy is obtained.

The 1.5-, 15-, and 150-volt ranges can now be checked at full scale and at various points along the scale, using suitable meters and an accurate voltage divider.

5.4.5.3 Calibration of 1500-Volt AC Range. This calibration involves adjustment of the capacitance-compensated resistance voltage divider



TYPE 1806-A ELECTRONIC VOLTMETER

that is switched into the circuit on this range. This divider is located on the upper right side of the instrument, immediately behind the front panel (see Figure 5-5). The calibration is accomplished in three steps: the resistance adjustment, the capacitance adjustment, and the adjustment for Boella effect in the high-voltage resistor.

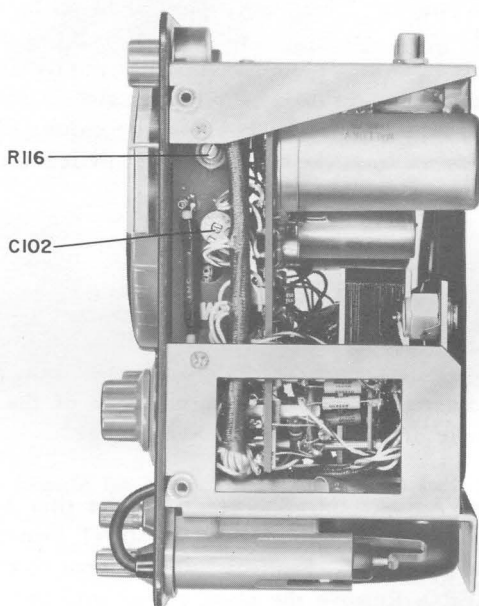

Figure 5-5. Right side view of voltmeter.

To adjust the resistance, proceed as follows:

Set the MEASUREMENT switch to AC and the VOLTS FULL SCALE switch to 150. Place the probe in its socket and connect a low-distortion, 400-cycle signal of 150 volts to the input binding posts. Adjust the amplitude of the source to give exactly full-scale deflection. Change the VOLTS FULL SCALE switch to the 1500-volt range and set R116 (on the ac divider board) so that the indication is exactly one-tenth of full scale (1.5 on the outer scale).

The following procedure should be used for the capacitance adjustment:

With the MEASUREMENT switch at AC, set the VOLTS FULL

SERVICE AND MAINTENANCE

SCALE switch to 150. Apply a low-distortion, 100-kc signal of 150 volts to the input binding posts. Adjust the amplitude of the source to give exactly full-scale deflection. Then change the VOLTS FULL SCALE switch to 1500 and set C102 (on the ac divider board) so that the indication is exactly one-tenth of full scale (1.5 on the outer scale).

The third necessary adjustment, that of the high-voltage resistor, gives the voltage divider a more flat frequency response in the vicinity of 10 kc (the region of the crossover from a resistance divider to a capacitance divider). The difficulty is due to a number of causes, including the Boella effect in the high-voltage resistor and the changing source impedance seen by the diode in the probe. To make the adjustment, insert a buttonhook-like tool into the hole in the ac divider board, and bend the striped high-voltage resistor (R114) away from, or nearer to, the board. The location and mounting of this resistor can be seen if the front panel is removed. It is mounted on long leads to facilitate the adjusting of its position. First, measure the frequency response of the high-voltage ac divider by applying an input signal of 150 volts to the binding posts, as described in the previous section. Make the measurements at 5, 10, 15, and 20 kc, and perhaps also at 2.5, 7, and 12 kc. Set the signal amplitude for full scale on the 150-volt range; then measure the response of the divider at one-tenth scale on the 1500-volt range. A departure from the correct adjustment of less than $\pm 2\%$ error can be corrected by the proper positioning of the resistor.

PARTS LIST

REF NO.	DESCRIPTION	RESISTORS	PART NO.
R1	Composition, 100 M Ω , 1/4 w		6099-7105
R2	Composition, 100 M Ω , 1/4 w		6099-7105
R101	Composition, 9.1 M Ω , $\pm 5\%$, 1/2 w		6100-5915
R102	Composition, 9.1 M Ω , $\pm 5\%$, 1/2 w		6100-5915
R103	Composition, 9.1 M Ω , $\pm 5\%$, 1/2 w		6100-5915
R104	Composition, 9.1 M Ω , $\pm 5\%$, 1/2 w		6100-5915
R105	Composition, 9.1 M Ω , $\pm 5\%$, 1/2 w		6100-5915
R106	Composition, 9.1 M Ω , $\pm 5\%$, 1/2 w		6100-5915
R107	Composition, 9.1 M Ω , $\pm 5\%$, 1/2 w		6100-5915
R108	Composition, 9.1 M Ω , $\pm 5\%$, 1/2 w		6100-5915
R109	Composition, 9.1 M Ω , $\pm 5\%$, 1/2 w		6100-5915
R110	Composition, 9.1 M Ω , $\pm 5\%$, 1/2 w		6100-5915
R111	Composition, 9.1 M Ω , $\pm 5\%$, 1/2 w		6100-5915
R112	Potentiometer, Composition, 2.5 M Ω , $\pm 20\%$		6010-2450
R113	Precision, 10 M Ω , $\pm 5\%$, 1/2 w		6100-6105
R114	Film, 22.5 M Ω , $\pm 5\%$, 2 w		6225-5225
R115	Film, 2.74 M Ω , $\pm 1\%$, 1/4 w		6350-4274
R116	Potentiometer, Composition, 500 K Ω , $\pm 10\%$		6010-2200
R117	Precision, 46 Ω , $\pm 1\%$, 1 w		6730-0046
R119	Film, 34.8 M Ω , $\pm 1\%$, 2 w		6590-5348
R120	Film, 348 K Ω , $\pm 1\%$, 1/8 w		6250-3348
R121	Film, 3.48 K Ω , $\pm 1\%$, 1/8 w		6250-1348
R122	Precision, 147 Ω , $\pm 1\%$, 1 w		6730-0147
R123	Composition, 51 Ω , $\pm 5\%$, 1/2 w		6100-0515
R124	Composition, 51 Ω , $\pm 5\%$, 1/2 w		6100-0515
R125	Composition, 8.2 M Ω , $\pm 5\%$, 1 w		6110-5825
R126	Composition, 100 K Ω , $\pm 5\%$, 5 w		6095-3100
R128	Film, 147 K Ω , $\pm 1/2\%$, 1/4 w		6351-3147
R129	Potentiometer, Wire-wound, 25 Ω , $\pm 10\%$		6050-0650
R130	Film, 14.6 K Ω , $\pm 1/2\%$, 1/4 w		6351-2146
R131	Film, 1.367 K Ω , $\pm 1/2\%$, 1/4 w		6351-1136
R132	Film, 187 K Ω , $\pm 1/2\%$, 1/4 w		6351-3187
R133	Composition, 620 K Ω , $\pm 5\%$, 1/2 w		6100-4625
R134	Composition, 249 K Ω , $\pm 1\%$, 1/2 w		6250-3249
R135	Composition, 107 K Ω , $\pm 1\%$, 1/2 w		6250-3107
R136	Film, 32.8 K Ω , $\pm 1/2\%$, 1/8 w		6251-2328
R137	Film, 1.60 K Ω , $\pm 1/2\%$, 1/4 w		6351-1160
R138	Composition, 54.5 K Ω , $\pm 1/2\%$, 1/2 w		6251-2545
R139	Film, 511 Ω , $\pm 1/2\%$, 1/8 w		6251-0511
R140	Film, 121 Ω , $\pm 1/2\%$, 1/8 w		6100-0121
R141	Composition, 1 K Ω , $\pm 5\%$, 1/2 w		6100-2105
R142	Potentiometer, Wire-wound, 10 K Ω , $\pm 10\%$		6050-1800
R143	Composition, 100 K Ω , $\pm 5\%$, 5 w		6095-3100
R144	Composition, 8.2 M Ω , $\pm 5\%$, 1 w		6110-5825
R145	Power, 4.7 Ω , $\pm 5\%$, 3 w		6680-9475
R146	Potentiometer, Composition, 10 K Ω , $\pm 10\%$		6010-0900
R147	Potentiometer, Composition, 10 K Ω , $\pm 10\%$		6010-0900
R148	Composition, 82 K Ω , $\pm 5\%$, 1 w		6110-3825
R149	Composition, 3.3 K Ω , $\pm 5\%$, 1/2 w		6100-2335
R150	Potentiometer, Composition, 10 K Ω , $\pm 10\%$		6010-0900

PARTS LIST (cont)

REF NO.	DESCRIPTION	PART NO.
R151	Composition, 82 K Ω , $\pm 5\%$, 1 w	6110-3825
R152	Composition, 120 K Ω , $\pm 5\%$, 1 w	6110-4125
R153	Composition, 75 K Ω , $\pm 5\%$, 1 w	6110-3755
R154	Composition, 27 K Ω , $\pm 5\%$, 1/2 w	6100-3275
R155	Composition, 2 K Ω , $\pm 5\%$, 1/4 w	6099-2205
R156	Composition, 2 K Ω , $\pm 5\%$, 1/4 w	6099-2205
R157	Composition, 2 K Ω , $\pm 5\%$, 1/4 w	6099-2205
R158	Composition, 2 K Ω , $\pm 5\%$, 1/4 w	6099-2205
R159	Power, 1.5 Ω , $\pm 5\%$, 3 w	6680-9155
R501	Composition, 91 Ω , $\pm 5\%$, 1/2 w	6100-0915
R502	Power, 0.47 Ω , $\pm 10\%$, 5 w	6660-9047
R503	Composition, 10 K Ω , $\pm 5\%$, 1/2 w	6100-3105
R504	Composition, 150 Ω , $\pm 5\%$, 1/2 w	6100-1155
R505	Composition, 1 K Ω , $\pm 5\%$, 1/2 w	6100-2105
R506	Composition, 240 Ω , $\pm 5\%$, 1/2 w	6100-1245
R507	Wire-wound, 75 Ω , $\pm 5\%$, 2 w	6760-0755
R508	Potentiometer, Wire-wound, 100 Ω , $\pm 10\%$	6050-0800
R509	Wire-wound, 330 Ω , $\pm 10\%$, 2 w	6760-1339

CAPACITORS

C1	9000 pf 900 v	1800-2610
C101	2 pf	1806-2000
C102	Trimmer, 5-20 pf, 500 v	4910-1150
C104	Plastic, 0.01 μ f, $\pm 10\%$, 400 v	4860-7648
C105	Plastic, 0.001 μ f, $\pm 10\%$, 400 v	4860-7308
C106	Plastic, 0.001 μ f, $\pm 10\%$, 400 v	4860-7308
C107	Ceramic, 0.01 μ f, 500 v	4406-3109
C108	Ceramic, 100 pf, $\pm 10\%$, 500 v	4404-1108
C109	Ceramic, 100 pf, $\pm 10\%$, 500 v	4404-1108
C110	Ceramic, 100 pf, $\pm 10\%$, 500 v	4404-1108
C111	Ceramic, 100 pf, $\pm 10\%$, 500 v	4404-1108
C112	Ceramic, 100 pf, $\pm 10\%$, 500 v	4404-1108
C501A	Electrolytic, 15 pf, +100-10%, 350 v	4450-3500
C501B		
C502A	Electrolytic, 15 μ f, +100-10%, 350 v	4450-3500
C502B		
C503A	Electrolytic, 750 μ f, +100-10%, 300 v	4450-0700
C503B		
C504	Ceramic, 0.0047 μ f, +80-20%, 500 v	4405-2479
C505	Ceramic, 0.0047 μ f, +80-20%, 500 v	4405-2479
C506	Wax, 0.22 μ f, $\pm 10\%$	5020-1150

MISCELLANEOUS

CR101	DIODE, 1N816	6083-1001
CR102	DIODE, 1N816	6083-1001
CR106	DIODE, 1N758A	6083-1012
CR501	DIODE, 1N3256	6081-1004
CR502	DIODE, 1N3256	6081-1004
CR503	RECTIFIER, 1N3660	6081-1005
CR504	RECTIFIER, 1N3660	6081-1005
CR505	DIODE, 1N91	6081-1009
CR506	DIODE, 1N750	6083-1003
F501	FUSE, 115 v, 0.3 amp	5330-0800
F502	FUSE, 115 v, 0.3 amp	5330-0800
F501	FUSE, 230 v, 0.15 amp	5330-0500
F502	FUSE, 230 v, 0.15 amp	5330-0500

PARTS LIST (cont)

REF NO.	DESCRIPTION	PART NO.
J101	JACK, Binding post	4060-0400
J102	JACK, Binding post	4060-0410
J103	JACK, Binding post	4060-1800
J104	JACK, Binding post	1806-1000
M101	METER	5730-0970
P501	PILOT LIGHT, 7 v, 0.059A Drake	7510-1380
PL101	PROBE ASSEMBLY (including C1, R1, R2)	1800-3500
PL501	PLUG, Power cable	4200-1903
Q101	TRANSISTOR, 2N3638	8210-1096
Q102	TRANSISTOR, 2N3638	8210-1096
Q501	TRANSISTOR, 2N1544	8210-1014
Q502	TRANSISTOR, 2N1304	8210-1304
Q503	TRANSISTOR, 2N1304	8210-1304
S101	SWITCH, Rotary wafer	7890-2940
S102	SWITCH, Rotary wafer	7890-2950
S103	SWITCH, Rotary wafer	7890-3470
S501	SWITCH, Rotary wafer	7890-2940
T501	TRANSFORMER	0485-4012
V1	TUBE, Type 7266	8380-7266
V101	TUBE, Type 5751	8380-5751
V102	TUBE, Type 12AU7	8370-0600
	ACCESSORIES SET, Probe tips and Ground Clips	1800-3510

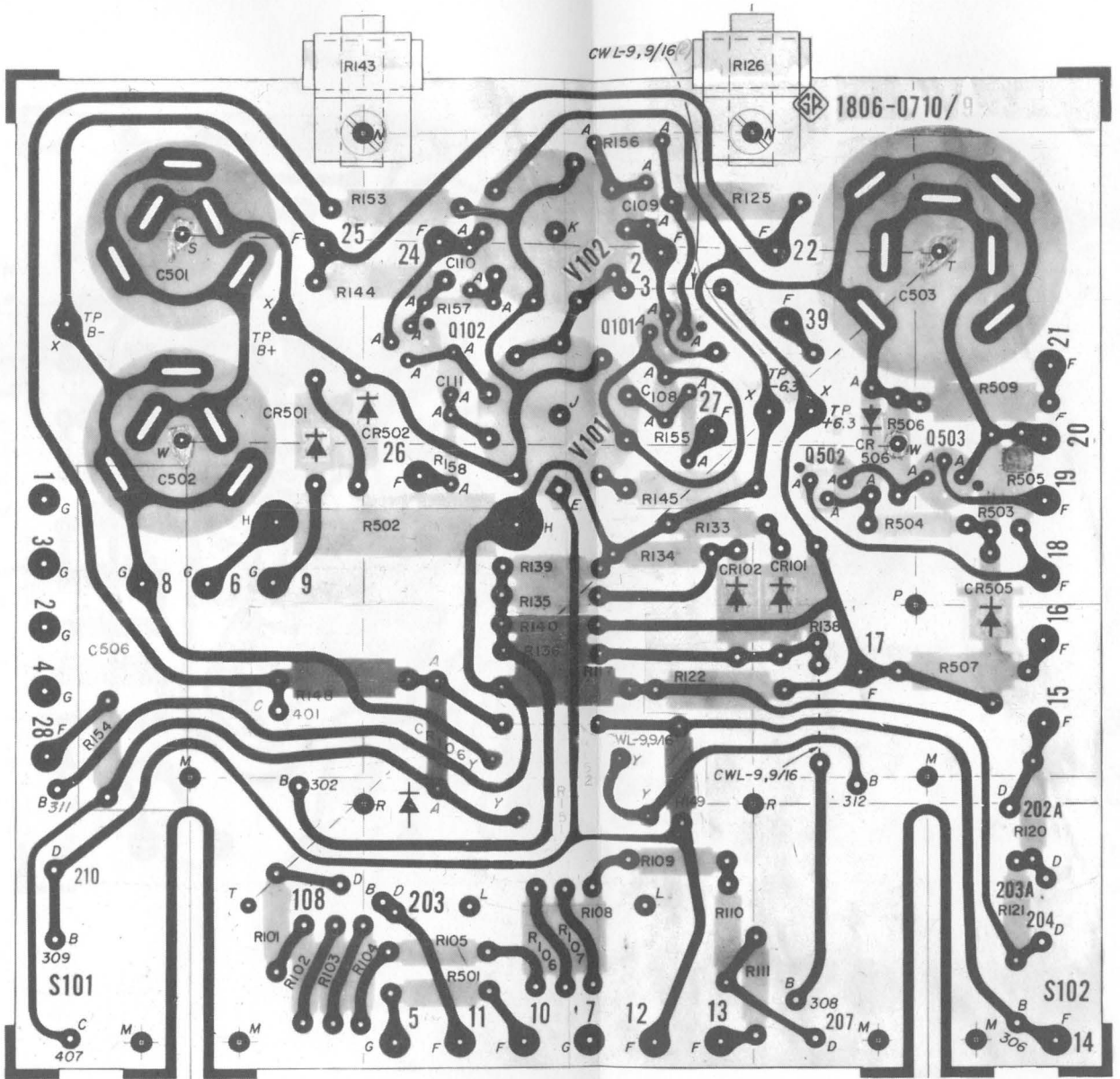

Figure 5-6. Main etched board.

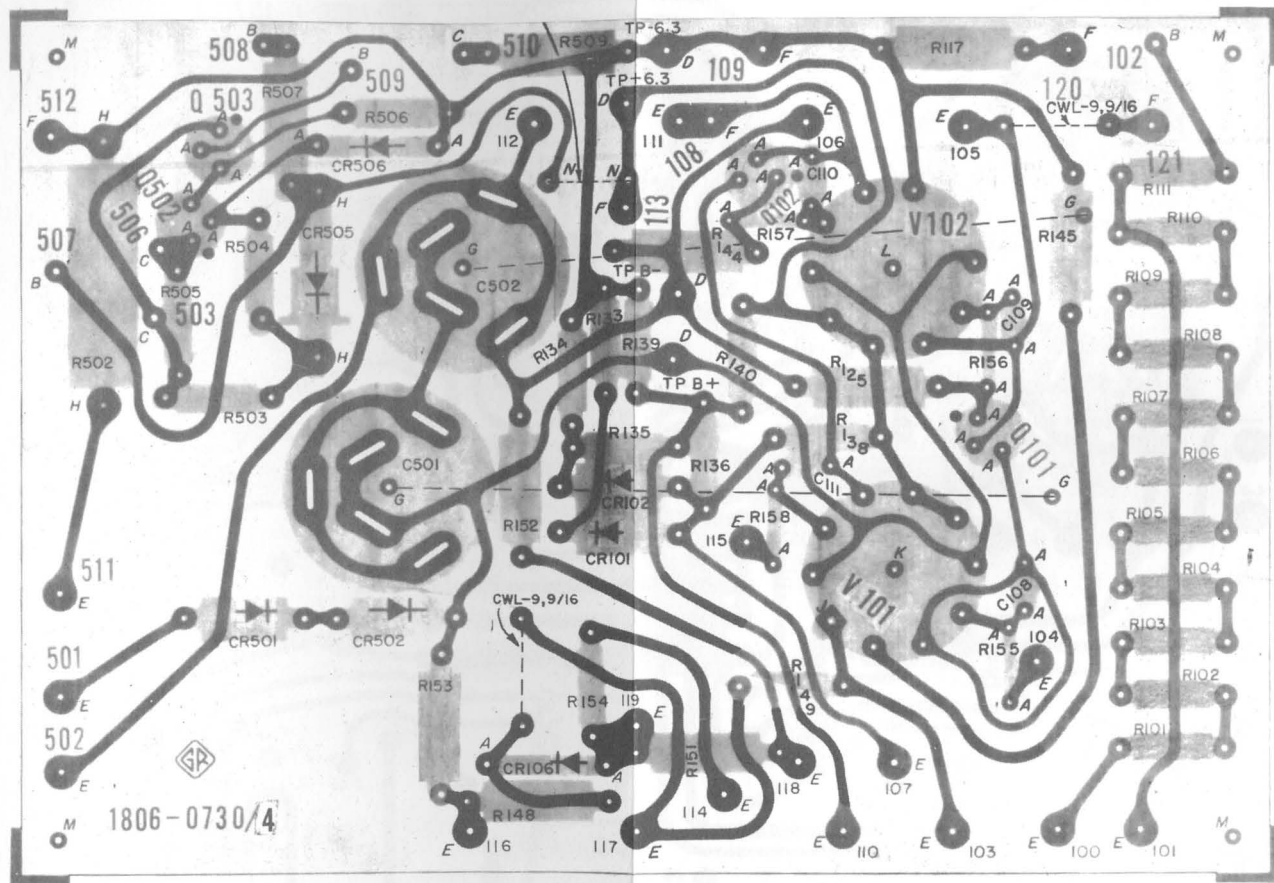
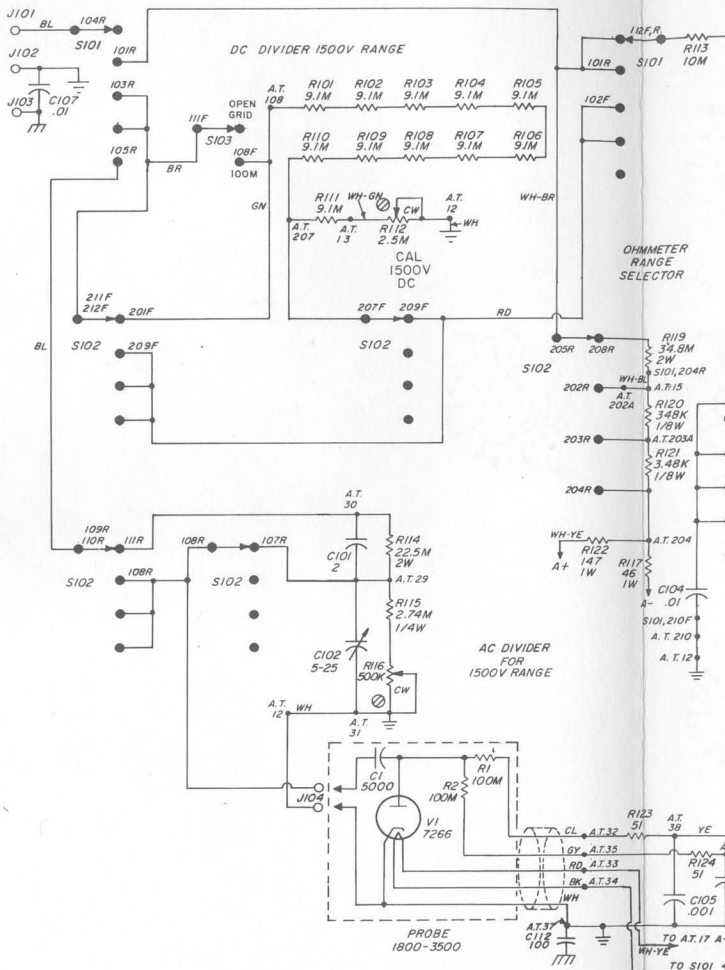
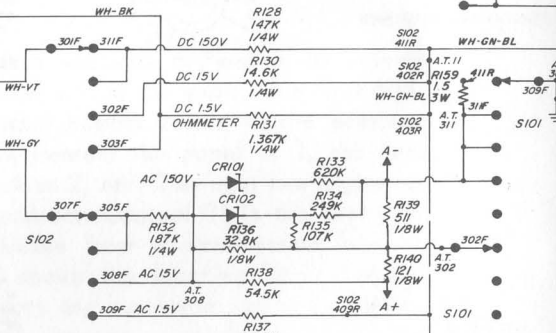
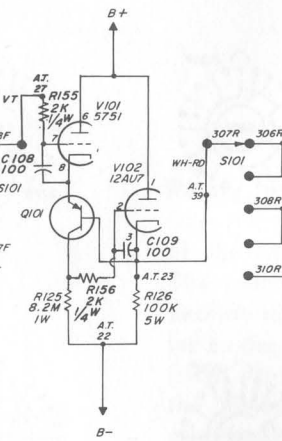
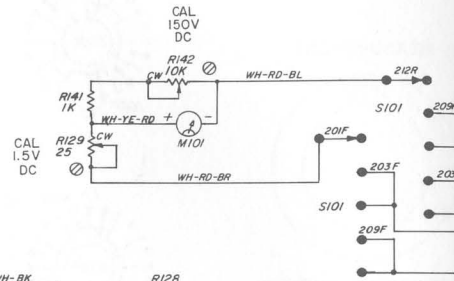

Figure 5-7. AC high-voltage divider etched board.



MEASUREMENT PANEL LEGEND

MEASUREMENT	PANEL LEGEND	VOLTS FULL SCALE	Ω
OFF	●	1500V	X1M
DC+	●	150V	X10K
DC-	●	15V	X100
AC	●	1.5V	X1



- NOTE UNLESS SPECIFIED
1. POSITION OF ROTARY SWITCHES SHOWN COUNTERCLOCKWISE.
 2. CONTACT NUMBERING OF SWITCHES EXPLAINED ON SEPARATE SHEET SUPPLIED IN INSTRUCTION BOOK.
 3. REFER TO SERVICE NOTES IN INSTRUCTION BOOK FOR VOLTAGES APPEARING ON DIAGRAM.
 4. RESISTORS 1/2 WATT.
 5. RESISTANCE IN OHMS K-1000 OHMS M-1 MEGOHM
 6. CAPACITANCE VALUES ONE AND OVER IN PICOFARADS, LESS THAN ONE IN MICROFARADS.
 7. ○ KNOB CONTROL.
 8. ⊕ SCREWDRIVER CONTROL.
 9. AT-ANCHOR TERMINAL.
 10. TP-TEST POINT.

FOR 115V OPERATION CONNECT A.T.1 TO A.T.3 & A.T.2 TO A.T.4 F501 & F502 = 0.3 AMP
 FOR 230V OPERATION CONNECT A.T.2 TO A.T.3 F501 & F502 = 0.15 AMP

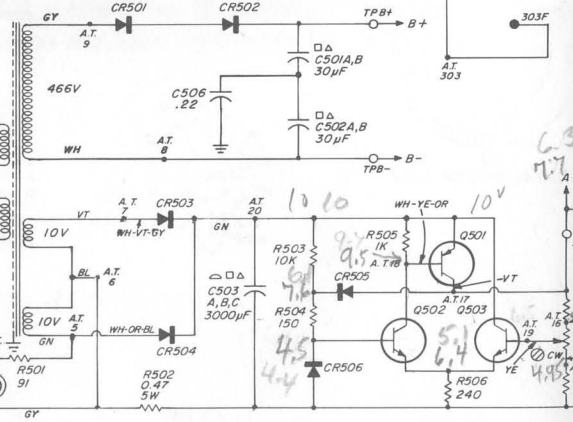

1.5V at ... sun cold.

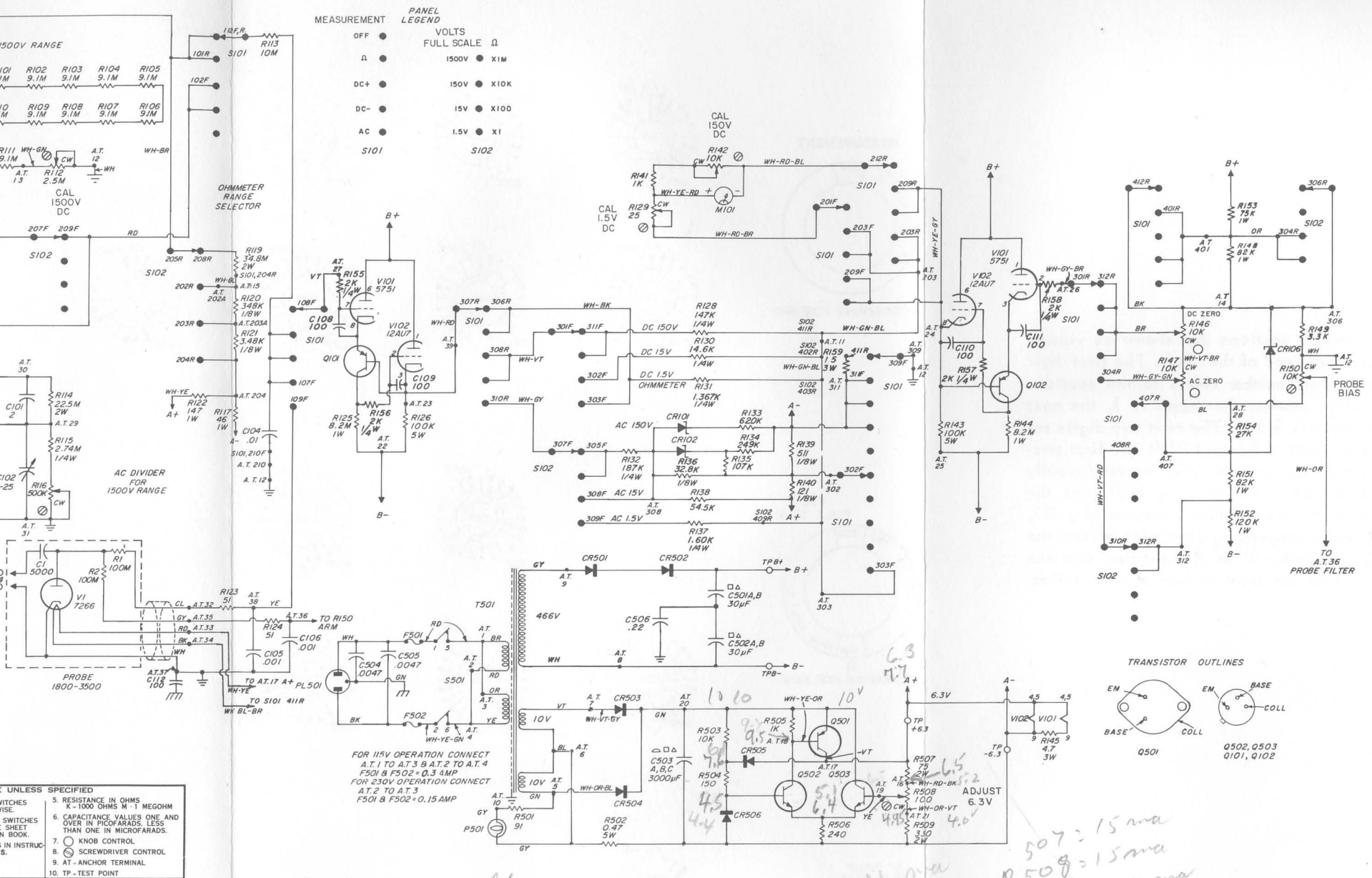

Voltages when cold.

*1.6
2.X
7.6
4.5*

*R503 = 10K
I = 2.4 / 10K = .24 ma*

*R504 = 150Ω
3.1 - 20.7*

*1.6
10K = .16 ma*

*507 = 15 ma
R508 = 15 ma
R509 = 15 ma*

Figure 5-8. Schematic diagram of Type 1806-A Electronic Voltmeter.

Rotary switch sections are shown as viewed from the panel end of the shaft. The first digit of the contact number refers to the section. The section nearest the panel is 1, the next section back is 2, etc. The next two digits refer to the contact. Contact 01 is the first position clockwise from a strut screw (usually the screw above the locating key), and the other contacts are numbered sequentially (02, 03, 04, etc.), proceeding clockwise around the section. A suffix F or R indicates that the contact is on the front or rear of the section.

MEASUREMENT

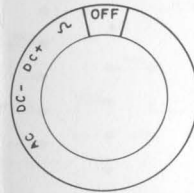

ENGRAVING FOR S101

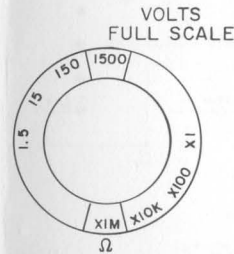

ENGRAVING FOR S102

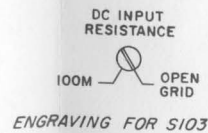

ENGRAVING FOR S103

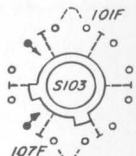
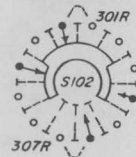
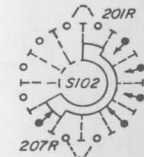
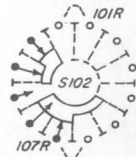
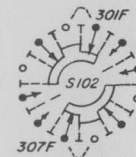
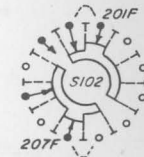
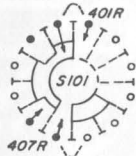
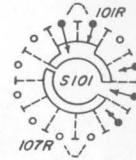
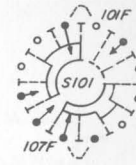

Figure 5-9. Switching diagram of Type 1806-A Electronic Voltmeter.